



CE

Avantgarde XXL 2

EN Instructions for use (user) 3

Table of contents

EN

1	Foreword	5
2	Product description	6
2.1	Function	6
2.2	Product overview	6
3	Intended use	7
3.1	Indications for use	7
3.2	Indications	7
3.3	Contraindications	7
3.3.1	Absolute Contraindications	7
3.3.2	Relative Contraindications	7
4	Safety	7
4.1	Explanation of warning symbols	7
4.2	General safety instructions	7
4.2.1	Safety notices regarding use	7
4.2.2	Safety notices for driving	8
4.3	Side effects	9
4.4	Nameplate and warning labels	9
5	Delivery	10
5.1	Scope of delivery	10
5.2	Options	10
5.3	Storage	10
5.3.1	Storage during daily use	10
5.3.2	Storage during extended disuse	10
6	Preparing the product for use	10
6.1	Assembly	10
7	Use	11
7.1	Further instructions for use	11
7.2	Getting in and transferring	11
7.3	Legrests	12
7.3.1	Folding the leg supports up and down	12
7.3.2	Removing and attaching the leg supports	13
7.3.3	Removing and fastening the calf strap	13
7.3.4	Adjusting the leg support	14
7.4	Seat and back upholstery	14
7.4.1	Removing and fastening the seat cushion	14
7.5	Backrest	15
7.6	Side panels	15
7.6.1	Removing the side panels	15
7.6.2	Adjusting the height of the forearm support	16
7.6.3	Adjusting the depth of the forearm support	16
7.7	Push handles	16
7.7.1	Adjusting the height of the push handles	16
7.7.2	Removing the push handles	17
7.8	Stabiliser bar	17
7.9	Drive wheels	18
7.9.1	Removing and mounting the drive wheels	18
7.9.2	Spoke protector	19
7.10	Caster wheels and caster forks	19
7.10.1	Approach in case of stiffness	20
7.11	Wheel locks	20
7.11.1	Using the wheel locks	20
7.11.2	Drum brake	21
7.11.3	Knee lever wheel lock for user and attendant	21
7.11.4	Knee lever wheel lock for one-handed operation (double handrims)	22

7.12	Frame accessories	22
7.12.1	Anti-tipper	22
7.12.1.1	Activating and deactivating the anti-tipper	23
7.12.2	Tip-assist	23
7.12.2.1	Using the tip-assist	23
7.13	Front frame	24
7.14	Lap belt (seat belt)	24
7.15	Transport wheels	25
7.15.1	Using the transport wheels	25
7.16	Crutch holder with hook-and-loop fastening strap	26
7.17	Head and neckrest	26
7.18	Tray	26
7.19	Additional options	27
7.20	Disassembly and transport	27
7.21	Use in vehicles for transporting persons with reduced mobility	28
7.21.1	Required accessories	29
7.21.2	Using the product in a vehicle	29
7.21.3	Restrictions for use	31
7.22	Care	32
7.22.1	Cleaning	32
7.22.1.1	Cleaning by hand	32
7.22.1.2	Cleaning the seat cushion	33
7.22.1.3	Cleaning belts/straps	33
7.22.2	Disinfection	33
8	Maintenance and repair	34
8.1	Maintenance	34
8.1.1	Maintenance intervals	34
8.1.2	Maintenance tasks	34
8.2	Repair	35
8.2.1	Inner tube, rim tape and tyre replacement	35
9	Disposal	36
9.1	Disposal information	36
10	Legal information	36
10.1	Liability	36
10.2	Warranty	36
10.3	Lifetime	36
11	Technical data	37
12	Appendices	38
12.1	Threshold values for wheelchairs transportable by train	38

1 Foreword

INFORMATION

Date of last update: 2023-12-19

- ▶ Please read this document carefully before using the product and observe the safety notices.
- ▶ Obtain instruction from the qualified personnel in the safe use of the product.
- ▶ Please contact the qualified personnel if you have questions about the product or in case of problems.
- ▶ Report each serious incident related to the product to the manufacturer and to the relevant authority in your country. This is particularly important when there is a decline in the health state.
- ▶ Please keep this document for your records.

INFORMATION

- ▶ New information regarding product safety and product recalls as well as the declaration of conformity can be obtained at ccc@ottobock.com or from the manufacturer's service department (visit www.ottobock.com for addresses).
- ▶ You can request this document as a PDF file at ccc@ottobock.com or from the manufacturer's service department. The PDF file can also be displayed in a larger size.

You have received a product that is very versatile for everyday use at home and outdoors.

In order to exclude injuries of any type, familiarise yourself with the handling, functions and intended use of the product before using it. These instructions for use provide you with the related necessary information.

Please note the following in particular:

- All users and/or their attendants must be trained by qualified personnel in the use of the product. In particular, users and/or attendants must be informed of the residual risks with the aid of the safety notices in the instructions for use (user).
- The product was adapted to the needs of the user. Subsequent changes may be made only by qualified personnel. We recommend checking the product settings **once per year** to ensure optimal treatment over the long term. Especially for users with a changing anatomy (for example body dimensions, weight), an adjustment at least **once every six months** is recommended.
- The product may differ from the variants shown. Not all options described in these instructions for use will be installed on the product.
- The manufacturer reserves the right to make technical changes to the model described in these instructions for use.

2 Product description

2.1 Function

The wheelchair is intended exclusively for transporting one person on the seat.
The wheelchair can be used on solid ground both indoors and outdoors.

2.2 Product overview



Maximum load: 180 kg

1	Push handle	7	Leg support
2	Back support, back support upholstery	8	Caster wheel
3	Side panel	9	Caster fork
4	Seat with seat cushion	10	Release button for quick-release axle
5	Seat pad	11	Wheel lock
6	Frame with crossbrace	12	Drive wheel with handrim

3 Intended use

The safe use of the product can only be ensured in case of intended use in accordance with the information contained in these instructions for use. The user is ultimately responsible for accident-free operation.

3.1 Indications for use

The wheelchair is intended for everyday indoor and outdoor use, by the user or an attendant, of people with temporary or permanent limitations of the ability to walk, inability to walk or difficulty standing up.

The product is suitable for users with intact skin whose anatomy (such as body dimensions and weight) permits the intended use of the product.

The wheelchair may only be used with the options listed on the product order form.

Ottobock assumes no liability for combinations with medical devices and/or accessories from other manufacturers outside the modular system.

Use with other products is the responsibility of the user. The combinations tested by the manufacturer are listed at www.ottobock.com.

3.2 Indications

- Minor to pronounced or complete restrictions of mobility

3.3 Contraindications

3.3.1 Absolute Contraindications



- None known

3.3.2 Relative Contraindications

- Failure to meet physical or mental requirements

4 Safety

4.1 Explanation of warning symbols

 WARNING	Warning regarding possible serious risks of accident or injury.
 CAUTION	Warning regarding possible risks of accident or injury.
 NOTICE	Warning regarding possible technical damage.

4.2 General safety instructions

4.2.1 Safety notices regarding use

- ▶ Always practise using the product in the presence of an attendant. Attendants are persons who understand the instructions for use, assume responsibility for operating the product and provide support.
- ▶ Use the product in accordance with local legal regulations during its entire lifetime.
- ▶ Do not exceed the maximum load (see the nameplate and "Technical data" section).
- ▶ Please note that certain accessories and add-on components will reduce the remaining load capacity.
- ▶ Attaching loads (e.g. backpacks) can adversely affect stability. Therefore, suspending additional loads on the product is not permitted.
- ▶ When persons with cognitive disabilities use the product, never leave them unattended. There is a risk of strangulation and suffocation due to components that can become loose (e.g. belts, small parts).
- ▶ Dispose of the packaging appropriately and in an environmentally-friendly manner. Keep packaging materials out of the reach of children.
- ▶ Only lift the product by firmly mounted components (e.g. on the main frame).
- ▶ Do not modify the settings established by the qualified personnel. Only the settings described for the user in the section "Use" may be adjusted independently. In case of problems, please contact the qualified personnel who adjusted your product.
- ▶ If any faults, defects or other hazards are detected, the product must be taken out of service immediately. This includes uncontrolled movements as well as unexpected or previously not noted sounds or odours that deviate significantly from the state of the product at the time of delivery. Contact the qualified personnel promptly.
- ▶ Activate the wheel lock each time before you get into or out of or transfer to or from the wheelchair.
- ▶ Do not step on the foot plates when getting in or out.

- ▶ In certain versions and with certain settings, the product tends to tip backwards due to its design to enable users with the corresponding physical prerequisites to manoeuvre quickly and nimbly. If the physical/mental conditions change, the product may no longer be used with these settings. Inform the qualified personnel immediately.
- ▶ Prior to activities that require bending forward in the seat (e.g. getting in, tying shoes), maximise the stability of the product. In order to do so, push the product backwards until the caster wheels turn forward.
- ▶ The user must not lean too far out of the seat when reaching for objects.
- ▶ The product includes moveable components that can pinch and crush the user (e.g. seat tilt, back support angle adjustment, leg supports, wheel locks). Do not reach between the moveable components.
- ▶ Please note that diagnostic examinations and therapeutic treatment with medical devices may result in improper interactions between your product and the devices used. Examinations and treatments must be carried out exclusively under the prescribed conditions.
- ▶ Do not expose the product to any extreme temperatures (e.g. prolonged direct sunlight, sauna, close proximity to heating appliances, prolonged extreme cold).
- ▶ Note that, in extreme temperatures, hypothermia or burns may occur in case of unprotected contact with components.
- ▶ Check your skin is undamaged where it is in contact with the product before and during use of the product.
- ▶ Note that excessive strain on the skin may result in skin damage or bruises. Pay careful attention to skin care and pressure redistribution. If skin damage occurs, stop using the product and consult qualified personnel.
- ▶ Have the seat and back support upholstery, seat cushions, padding and covers replaced immediately in case of damage.
- ▶ Note that dirt, salt and sand may damage the wheelchair components (e.g. bearings, joints). Always clean them promptly and observe the maintenance and care instructions.
- ▶ Keep all ignition sources, especially lit cigarettes, away from the seat and back support upholstery, seat cushions, pads and covers.

4.2.2 Safety notices for driving

General

- ▶ Practise on level, open ground first.
- ▶ Learn with the support of an assistant how the product reacts to changes in centre of gravity, e.g. downward or upward slopes, inclines or when overcoming obstacles.
- ▶ Always step into the product from the side if possible.
- ▶ Do not reach between the drive wheel and wheel lock or drive wheel and side panel when driving the product.
- ▶ Do not reach into the spokes of the rotating drive wheels.
- ▶ Note that heat generated when braking with handrims can cause burns due to inadequate hand protection. Wear wheelchair gloves when travelling at high speeds.
- ▶ Adapt your speed to the conditions and reduce it accordingly in danger areas, on downslopes and when crossing obstacles. Typical hazards and obstacles are:
 - narrow paths along waterways, slopes, precipices (e.g. quay walls, embankments etc.),
 - confined spaces or areas,
 - steps, kerbs,
 - steep downslopes (e.g. in the mountains, towards roads),
 - unpaved terrain (construction sites, crossings, level crossings),
 - snow-covered paths.
- ▶ Only manoeuvre backwards over short distances and on even surfaces.
- ▶ Only the push handles may be used for pushing or overcoming obstacles. Use the tip-assist if necessary. The attendant should make sure that he/she has a secure stance and firm grip (on both sides).
- ▶ Wear light-coloured clothing or clothing with reflectors when driving in the dark. Install active lighting on your product. Ensure that the reflectors on the product are clearly visible.
- ▶ When using public transport, always observe the currently applicable legal requirements and the safety notices of the public transport operator.
- ▶ Use the permanently installed seats on public transport. If you need to use your wheelchair as a seat, use the designated wheelchair spaces and safety equipment provided. Always ensure that you are held in place securely.

- ▶ The wheelchairs in this series comply with the minimum technical requirements for wheelchairs transportable by train. Please note that it is possible that not every individual wheelchair will fulfil the minimum requirements due to the variation in designs (please see see page 38 for further details).

Obstacles (steps, kerbs, tracks)

- ▶ Use available technical equipment (e.g. ramps, lifts) to negotiate stairs and obstacles. If such facilities are not available, ask attendants to help you.
- ▶ Raise the front wheels before crossing obstacles. If you are inexperienced, use an anti-tipper and/or have an assistant or attendant help or secure you.
- ▶ Approach obstacles at right angles and drive over them in one go.
- ▶ Do not “jump” the chair down from higher surfaces.
- ▶ Do not lean out of the wheelchair while crossing obstacles.
- ▶ Do not use escalators.
- ▶ Negotiate level crossings so the caster wheels cannot get caught in the gap between the rail and the road surface.

Inclines and downslopes

- ▶ Cross obstacles or negotiate inclines or downslopes only if they are within the permitted maximum limits. For more information, see the section "Technical data" (see page 37).
- ▶ Do not cross over any obstacles while driving on inclines and downslopes.
- ▶ Before negotiating slopes or crossing obstacles, the seat tilt must be lowered (horizontal position of the seat). It is advisable to incline the seat tilt slightly to the rear when driving downhill.
- ▶ Avoid getting into or out of the product on inclines and downslopes.
- ▶ Never park the product on slopes when the user is in the seat.
- ▶ Do not drive downhill backwards. Briefly manoeuvring on ramps is permitted with supervision (for example, when exiting a vehicle for transporting persons with reduced mobility).

4.3 Side effects

The following side effects may occur during use of the product:

- Neck, muscle and joint pain
- Circulatory disorders, pressure sores

Contact a doctor or therapist in case of problems.

4.4 Nameplate and warning labels

The product can be clearly identified by the information on the nameplate. In case of enquiries and orders for spare parts and accessories, the product's serial number in particular must be kept ready.

The nameplates are found on the frame.

Label	Meaning
	A Name of the product
	B CE marking
	C Maximum load (see section “Technical data”)
	D Manufacturer information/address
	E Serial number ¹⁾
	F Manufacturing date ²⁾
	G Symbol for medical device
	H WARNING! Read the instructions for use before using the product. Observe important safety-related information (e.g. warnings, precautions).
	I Manufacturer’s reference number for the product variant
	J Serial number (PI) ^{3),1)}
	K Global Trade Item Number (DI) ⁴⁾

¹⁾ YYYY = year of manufacture; WW = week of manufacture; PP = production site; XXXX = sequential production number

²⁾ YYYY = year of manufacture; MM = month of manufacture; DD = day of manufacture

³⁾ UDI-PI to GS1 standard; UDI = Unique Device Identifier, PI = Production Identifier

4) UDI-DI to GS1 standard; UDI = Unique Device Identifier, DI = Device Identifier

Label	Meaning
	<p>Fixation point to attach the product in vehicles for transporting persons with reduced mobility.</p> <p>The product is approved as a seat in a vehicle for transporting persons with reduced mobility only if this symbol is stuck onto the fixation points of the product.</p>

5 Delivery

5.1 Scope of delivery

- Wheelchair ready for use
- Instructions for use (user)
- Instructions for use for accessories (depending on equipment)

5.2 Options

The standard model can be fitted to the user's personal requirements thanks to a large range of options. For use of these options: see page 11 ff.

5.3 Storage

5.3.1 Storage during daily use

The product must always be parked so it is protected against external influences.

5.3.2 Storage during extended disuse

The product must be stored in a dry place. Specific information for extended storage: see page 37.

It is not necessary to disassemble the product.

Maintain sufficient clearance from sources of heat. If the product is parked for an extended period of time or the tyres overheat (e.g. in the vicinity of radiators or in case of exposure to strong sunlight behind glass), the tyres may become permanently deformed.

During extended storage, the knee lever wheel lock on wheelchairs with PU tyres (= tubeless tyres) must be released since tyre deformation may otherwise result.

6 Preparing the product for use

6.1 Assembly

⚠ CAUTION

Exposed pinch points

Crushing, pinching due to incorrect handling

- ▶ When folding the wheelchair out or together, only grip by the specified components.

⚠ CAUTION

Failure to verify readiness for use before putting into service

Tipping, falling due to incorrect adjustment or installation

- ▶ Before you start using the wheelchair for the first time, check the selected wheelchair settings with the support of qualified personnel.
- ▶ After every assembly, check the drive wheels are properly mounted. The quick-release axles must be firmly locked in the quick-release axle mounting.
- ▶ Pay particular attention to the stability against tipping, free running of the drive wheels and correct function of the brakes/wheel locks.
- ▶ Check the tyre pressure. The correct tyre pressure is printed on the sidewall. Ensure that the pressure is the same in both tyres.

INFORMATION

On the topic of disassembly/transport: see page 27.

It takes just a few simple steps to prepare the wheelchair for use:

- 1) Attach the drive wheels to the quick-release axle mounting (see fig. 2):
 - Press the button on the quick-release axle.
 - Attach the drive wheel to the quick-release axle mounting and release the button on the quick-release axle.
 - The quick-release axles must not be removable after the press button is released.
- 2) Unfold the wheelchair:
 - Loosen the safety strap (see fig. 3).
 - Push the wheelchair apart with the flats of your hands (see fig. 4).

INFORMATION: While next to the wheelchair, tip it slightly towards you and press on the edge of the seat upholstery closest to you.
- 3) **If necessary:** Attach the leg supports (see page 13).
Fold down the foot plates. With a single-panel foot plate, make sure the support of the foot plate is locked into the receiver (see fig. 5; see page 12).
- 4) **If necessary:** Fit the seat cushion (see page 14).



7 Use

7.1 Further instructions for use

- The recommended overall width for manual wheelchairs in an operational state is **700 mm**. This specification should ensure unhindered use of escape routes, for example. Note that the product dimensions can exceed the recommended values for dimensions and the movement range of manually powered wheelchairs in variants with very large seat widths (see see page 37 ff.).

7.2 Getting in and transferring

Users can choose the method for getting into and out of the wheelchair which is most suitable for them. The respective procedure should be discussed and practised with a therapist.

As a rule, the frame tubes, seat bottom or side panels can be used as supports for getting into the wheelchair.

If getting in independently is not possible, transferring or getting in always has to be performed with the help of an assistant. The manufacturer also offers transfer aids for getting in, such as transfer boards.

7.3 Legrests

The leg supports support the user's feet.

The height of the leg support has been adjusted by qualified personnel to the length of the user's lower legs.

The angle of the foot support has been set by the qualified personnel so that it allows the ankles to rest in a comfortable position.

Different leg support types and other accessories may be installed depending on the order:

Single-panel, angle-adjustable leg support (see fig. 6)

The depth of the foot supports is either **125 mm** or **160 mm**.

Segmented, angle-adjustable leg support (see fig. 7)

The foot plates are joined in the centre by a fastening mechanism. The depth of the foot supports is **160 mm**.



Locking mechanism for single-panel foot plate (see fig. 10)

The locking mechanism prevents inadvertent loosening of the foot plate, especially for users with spasticity.

Lateral heel blocks for the foot plate (see fig. 8)

Lateral heel blocks prevent the feet from slipping off the leg supports. They can be combined with all segmented and single-panel foot plates with a depth of **160 mm**.

Adjustable lateral heel blocks for the foot plate (see fig. 9)

Lateral heel blocks prevent the feet from slipping off the leg supports. With this version, the position can be additionally adjusted by qualified personnel.

Heel strap (example: see fig. 11, item 2)

The heel strap offers additional support for the user's feet. This prevents the feet from sliding off the foot plate into the danger area.



7.3.1 Folding the leg supports up and down

- 1) Hold on to the edge of the foot plate and fold it up (not illustrated).
- 2) Fold the foot plate down:

- **Only for leg supports with a locking mechanism for single-panel foot plates:** Pull out the locking mechanism and swing the foot plate up (see fig. 10). While folding down, make sure the support of the foot plate is locked into the receiver.
- **Only for leg supports with single-panel foot plate:** Make sure the support of the foot plate is locked into the receiver. (not illustrated)
- **Only for leg supports with segmented foot plates:** Make sure the fastening mechanism of the foot plate engages (see fig. 11, item 1).

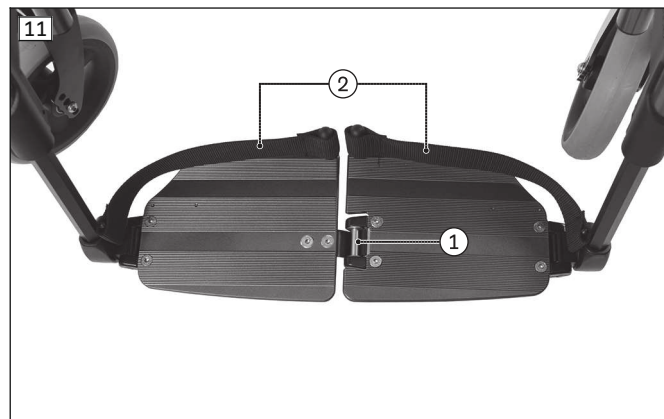

7.3.2 Removing and attaching the leg supports

Removing the leg supports

- 1) Fold the foot plate up.
- 2) Pull back the release lever (see fig. 12, item 1).
- 3) Remove the leg support:
 - **Frame model XXL 2 contoured:** Fold the leg support out by 90° (see fig. 12, item 2). Only now can the leg support be lifted up and off.
 - **Frame model XXL 2:** The leg support can be removed immediately without swinging it away.

Attaching the leg supports

- 1) Insert the leg support:
 - **Frame model XXL 2 contoured:** Hold the leg support 90° out to the side and insert it into the leg support retainer (see fig. 12, item 2).
 - **Frame model XXL 2:** The leg support can be inserted into the leg support retainer immediately without swinging it away.
- 2) Swing the leg support into the direction of travel until it engages.
- 3) Fold the foot plate down.



7.3.3 Removing and fastening the calf strap

The calf strap offers additional support for the user's legs. It also prevents the feet from sliding off the foot plate into the danger area. The calf strap can be removed for cleaning.

Attaching the calf strap

- 1) Open all hook-and-loop closures.
- 2) Pass the calf strap through the eyelets on the swivel segments (see fig. 14, item 1).
- 3) Adjust the length and fasten the hook-and-loop closure (not pictured).

Removing the calf strap

- 1) Open all hook-and-loop closures.
- 2) Remove the calf strap from the frame tube.

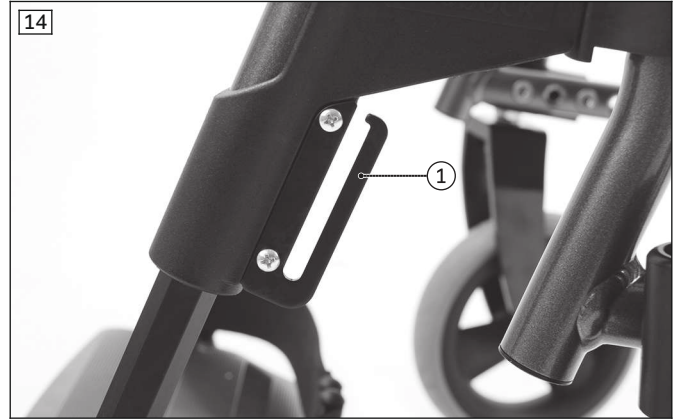

7.3.4 Adjusting the leg support

Further adjustments may be made only by qualified personnel.

7.4 Seat and back upholstery

The product is equipped with seat and back upholstery. Hook-and-loop fasteners on the seat upholstery are used to attach the seat cushion. The seat cushion ensures pressure relief during use of the wheelchair. It was chosen by qualified personnel according to the needs of the user.

The seat upholstery on model XXL 2 has an additional pocket with a hook-and-loop closure under the seat bottom (see fig. 15).

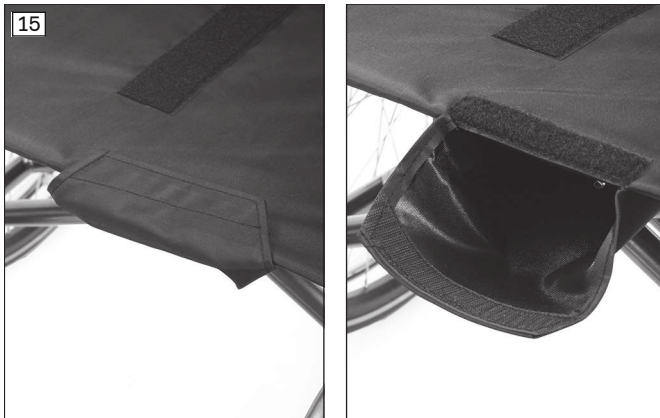

7.4.1 Removing and fastening the seat cushion

The seat cushion can be removed for cleaning.

After cleaning, the seat cushion is placed on the seat upholstery and secured against sliding by pressing it onto the hook-and-loop fastener on the seat upholstery.

7.5 Backrest

⚠ WARNING

Incorrect use of back support angle adjustment

Falling, tipping over due to operation without anti-tipper

- ▶ Note that adjusting the back support angle shifts the centre of gravity. Only use the back support angle adjustment with the anti-tipper activated.
- ▶ Drive in street traffic only with a vertical back support.

The product can be equipped with a fixed or optionally an angle-adjustable back support.

Height-adjustable/adaptable back support (not illustrated)

The different versions of the back support permit height adjustments in **25 mm** increments within an adjustment range of **250 to 500 mm**.

Angle-adjustable back support (see fig. 16)

The inclination of the back support to the seat bottom can be adjusted by qualified personnel from **-9° to +15°** in 6° increments. The angle-adjustable back support also permits an extremely small folding size.



7.6 Side panels

The side panels protect the user and his/her clothing from getting dirty.

If armrests have been installed on the wheelchair, they offer the user additional support for the forearms.

7.6.1 Removing the side panels

To make getting into the wheelchair easier and for transportation, the side panel with arm pad can be removed.

⚠ CAUTION

Incorrect use of the side panel

Health hazard, risk of breakage of the side panel mounting due to incorrect use

- ▶ Fold the side panel down such that it engages audibly in the side panel mounting.

INFORMATION

When using the side panel with arm pad in combination with an angle-adjustable back support, the back support angle can only be adjusted from **+3° to -15°**.

Folding back/removing

- 1) Press the release lever of the side panel with arm pad (see fig. 17).
- 2) Fold up the side panel with arm pad up by approx. **90°**.
- 3) Turn the side panel with arm pad towards the back support and pull it out of the side panel mounting (see fig. 18).



Attaching/closing

- 1) Turn the side panel with arm pad towards the back support and insert it into the side panel mounting (see fig. 18).
- 2) Rotate the side panel with arm pad parallel to the seat surface and fold it down.
- 3) Ensure that the side panel with arm pad engages audibly in the mounting on the frame tube.

7.6.2 Adjusting the height of the forearm support

The height of the forearm support on the side panel can be set to various positions without the use of tools.

- 1) Pull the release lever in the round opening in the side panel upwards and adjust the desired height. (see fig. 19, item 1).
- 2) Let go of the release lever. The forearm support locks into place automatically.

7.6.3 Adjusting the depth of the forearm support

The depth of the forearm support long, "depth-adjustable" on the side panel with arm pad, can be set to various positions without the use of tools.

- 1) Press the release button in the forearm support and adjust the desired depth (see fig. 20, item 1).
- 2) Let go of the release button. The forearm support locks into place automatically.



7.7 Push handles

The push handles make pushing the wheelchair easier for the attendant.

Some of the push handle designs allow the height to be adjusted to suit the needs of the attendant.

7.7.1 Adjusting the height of the push handles

To enable ergonomic pushing by the attendant, the wheelchair can be equipped with height-adjustable push handles.

- 1) Release the clamping lever.
- 2) Adjust the height of the push handle.
INFORMATION: Adjust both push handles to the same height.
- 3) Engage the clamping lever.



7.7.2 Removing the push handles

Push handles of the “height-adjustable, removable” type can be removed from the back support tube when needed.

Removing/installing the push handles

- 1) Release the clamping lever (see fig. 23, item 1).
 - 2) Push in the tripod spring (see fig. 23, item 2) and pull the push handle up and out of the adapter (see fig. 23, item 3).
 - 3) To install, push in the tripod spring again and insert the push handle into the adapter.
 - 4) Firmly close the clamping lever (see fig. 23, item 1).
- Both push handles must be installed at the same height.



7.8 Stabiliser bar

The stabiliser bar between the push handles increases the wheelchair's stability, especially in case of high loads. It has to be opened before folding the wheelchair.

Please note: Using the stabiliser bar for pushing and pulling the wheelchair is not permitted. Always use the push handles for this purpose.

Opening the stabiliser bar

- 1) Open the star handle on the right side (see fig. 25, item 1).
- 2) Fold the stabiliser bar down (see fig. 25, item 2).

Closing the stabiliser bar

- 1) Fold the stabiliser bar up until the opening is against the screw of the star handle.
- 2) Hand-tighten the star handle.

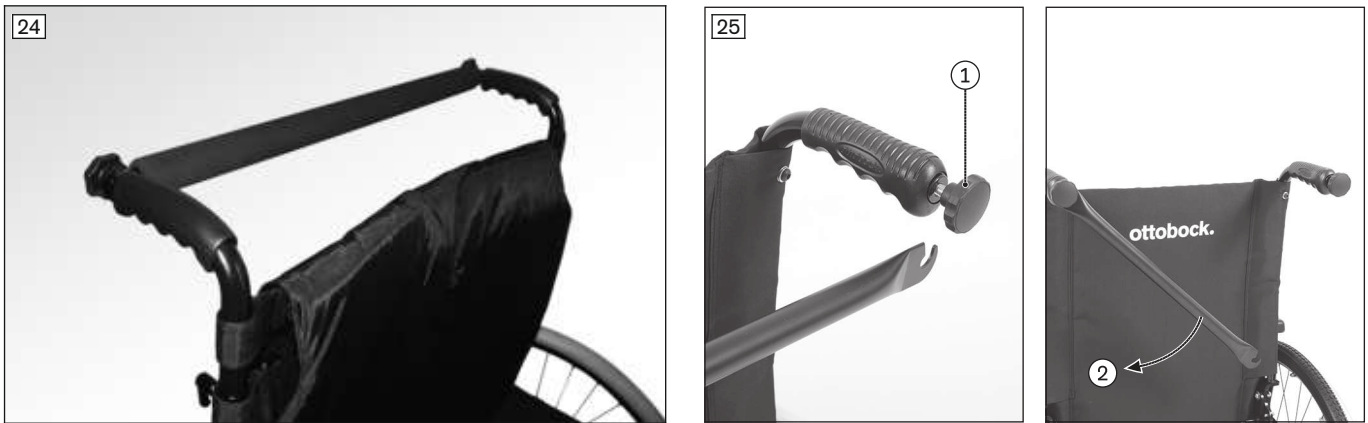

7.9 Drive wheels

⚠ WARNING

Improper assembly of removable wheels

Tipping, falling over of the user due to wheels coming off

- ▶ After each assembly, verify the proper fit of the removable wheels. The quick-release axles must be firmly locked in the wheel attachment.

⚠ WARNING

Defective tyres

Accidents/falling due to poor traction, reduced braking force or lack of manoeuvrability

- ▶ Maintain sufficient tyre pressure. Note the information in the section "Technical data" or on the tyre sidewall.
- ▶ Ensure that the pressure is the same in both tyres.
- ▶ Ensure that the tyres have sufficient tread depth.

The wheelchair is moved, steered, braked and stopped with the help of the handrims on the drive wheels. To make transport easier, drive wheels with quick-release axle can be taken off the wheelchair.

7.9.1 Removing and mounting the drive wheels

⚠ CAUTION

Incorrect removal/attachment of the wheels

Tipping, falling due to incorrect installation

- ▶ The user is not permitted to sit in the wheelchair during wheel replacement.
- ▶ For changing wheels, set the wheelchair onto a solid surface.
- ▶ To change the wheels, secure the wheelchair against tipping over or rolling away.
- ▶ If the drive wheel does not lock securely or has too much sideways play, contact the qualified personnel promptly.

- 1) Release the wheel lock.
- 2) Use your thumb to press in the push-button on the quick-release axle (see fig. 26, item 1).
- 3) Remove or mount the drive wheel.

After mounting: The drive wheels must not be removable after releasing the push-button on the quick-release axle.



7.9.2 Spoke protector

The spoke protector prevents the fingers from getting caught in the wheel spokes.

7.10 Caster wheels and caster forks

⚠ WARNING

Failure of caster wheels or caster forks

Falling, severe injury due to the wheelchair tipping over

- ▶ Regularly inspect the caster wheels and caster forks for damage.
- ▶ Regularly clean and oil the caster wheel axles and the threaded axles on the caster forks, especially in case of stiffness.
- ▶ Inform the responsible qualified personnel in case of permanent changes to the driving characteristics.

The combination of caster wheels and caster forks ensures the ability to hold a straight line and navigate bends securely.

The caster wheels and caster forks have been chosen by the qualified personnel according to the needs of the user.

Some options can expand the functions of the caster forks and caster wheels:

Caster wheel adapter for high front seat heights (see fig. 27)

Increases the front seat height by **35 mm**. Expands the adjustment range of the lower leg lengths. Also offers more freedom of movement for the feet due to caster wheels being positioned further to the outside.

Caster wheel adapter for low front seat heights (see fig. 28)

Reduces the front seat height by **35 mm**. Also offers more freedom of movement for the feet due to caster wheels being positioned further to the outside.



Alternative caster wheels

Standard caster wheels (see illustration above) or alternative caster wheels may be installed (e.g. Froglegs caster wheels with aluminium hubs (see fig. 29).



7.10.1 Approach in case of stiffness

In case of stiffness, the caster wheel axles should be cleaned and oiled.

Oiling the caster axle

- 1) Remove dirt (such as hairs) from the caster axle between the caster wheel and caster fork.
- 2) Lubricate the caster axle between the caster wheel and caster fork with a few drops of thin, resin-free oil (sewing machine oil).

7.11 Wheel locks

⚠ WARNING

Improper use of the wheel lock

Falls due to abrupt braking, rolling away of the product, crushing of hands

- ▶ Do not use the wheel lock as a driving brake.
- ▶ Always engage the wheel lock on both sides.
- ▶ Engage the wheel lock to prevent the product from moving when it is parked on uneven ground or during transfers (e.g. into a car).
- ▶ Do not reach between the rear wheel and the wheel lock when driving the product.
- ▶ Ensure that the knee lever wheel lock is properly adjusted (max. **5 mm** gap between wheel lock bolt and tyre). The wheel lock bolt must lock the drive wheel securely when stationary.
- ▶ Please contact the qualified personnel who adjusted your product for readjustment of the wheel lock.

The wheel locks secure the parked wheelchair against rolling away.

Different wheel lock types may be installed depending on the order.

7.11.1 Using the wheel locks

Activating and deactivating the knee lever wheel lock

- 1) Push the handle of the knee lever wheel lock forward (see fig. 30).
→ The wheel lock bolt secures the wheel.
- 2) Pull the wheel lock lever upwards (see fig. 30).
→ The wheel lock lever releases the wheel.

Plug-on wheel lock lever extension (see fig. 31)

The wheel lock lever extension facilitates use of the knee lever wheel lock. For easier transfer, the wheel lock lever can be folded.



7.11.2 Drum brake

The drum brakes allow the attendant to slow the wheelchair easily and safely by activating the wheel lock lever on the push handles.

Activating and deactivating the drum brake

- 1) Pull the wheel lock lever (see fig. 32, item 1).
- 2) If necessary, secure the wheel lock lever by additionally actuating the lock slide (see fig. 32, item 2).
- 3) Deactivate the wheel lock by actuating the wheel lock lever again or pressing the lock slide.

The drive wheels can still be removed via the quick-release axles when the wheel lock lever is released (see fig. 33).



7.11.3 Knee lever wheel lock for user and attendant

This wheel lock type can be used by both the user and an attendant.

INFORMATION

- ▶ Operation of the wheel lock by the user is the same as for the knee lever wheel lock described above.
- ▶ Operation of the wheel lock levers by the attendant is the same as for the drum brake described above.
- ▶ Note that when the brake is activated, only the person (user, attendant) can deactivate the brake again.

Activation/deactivation by the user

- 1) Push the handle of the knee lever wheel lock forward (see fig. 30).
→ The wheel lock bolt secures the wheel.
- 2) Pull the wheel lock lever upwards (see fig. 30).
→ The wheel lock bolt releases the wheel.

Activation/deactivation by the attendant

- 1) Pull the wheel lock lever (see fig. 32, item 1).
- 2) Secure the wheel lock lever by additionally actuating the lock slide (see fig. 32, item 2).
→ The wheel lock bolt secures the wheel.

- 3) Deactivate the wheel lock by actuating the wheel lock lever again or pressing the lock slide (see fig. 32, item 1/2).
→ The wheel lock bolt releases the wheel.

7.11.4 Knee lever wheel lock for one-handed operation (double handrims)

Depending on the installation, this wheel lock type can be operated either on the right or left side and ensures safe locking of both rear wheels with a pull-wire system.

Activating/deactivating the knee lever wheel lock for one-handed operation

INFORMATION

Note that when the wheel lock lever extension option is chosen, the lever extension must always be attached when releasing or engaging the wheel lock.

- 1) Push the handle of the knee lever wheel lock forward (see fig. 34).
→ The wheel lock bolt secures the wheel.
- 2) Pull the wheel lock lever upwards (see fig. 34).
→ The wheel lock bolt releases the wheel.



7.12 Frame accessories

7.12.1 Anti-tipper

⚠ WARNING

Incorrectly adjusted anti-tipper

Tipping over, falling of the user due to errors in handling the product

- ▶ If only one attendant helps in overcoming steps, the attendant must first deactivate the anti-tipper so that it cannot collide with the steps during transport.
- ▶ The attendant must activate the anti-tipper again after overcoming the steps.

⚠ WARNING

Anti-tipper not activated

Tipping over, falling of the user due to improper operation of a safety device

- ▶ Ensure that an installed anti-tipper is activated before travelling over obstacles and on inclines.
- ▶ The anti-tipper has to engage audibly prior to use. Proper engagement must be checked by the user or an attendant.
- ▶ The use of an anti-tipper is highly recommended for transfemoral amputees and inexperienced users.

⚠ WARNING

Incorrectly adjusted anti-tipper

Risk of falling as a result of incorrectly adjusted anti-tipper.

- ▶ The anti-tipper may only be adjusted by qualified personnel.

The anti-tipper prevents the wheelchair from tipping backwards when overcoming obstacles and going uphill.

7.12.1.1 Activating and deactivating the anti-tipper

A mounted anti-tipper must always be active.

When overcoming obstacles (such as steps and curbs that are not lowered) **upwards**, the anti-tipper rollers contact the ground.

When overcoming obstacles (such as steps and curbs that are not lowered) **downwards**, the anti-tipper has to be deactivated by the user or attendant to avoid damaging the anti-tipper.

Activation

- 1) The anti-tipper is pressed down with the hand or foot (see fig. 35, item 1; see fig. 36, item 1).
- 2) Swing the anti-tipper back and allow it to engage (see fig. 35, item 2; see fig. 36, item 2).

Deactivation

- 1) From above, press on the anti-tipper with the hand or foot until it disengages (see fig. 37, item 1; see fig. 38, item 1).
- 2) Rotate the anti-tipper forward by **180°** and release it (see fig. 37, Pos. 1; see fig. 38, Pos. 1).

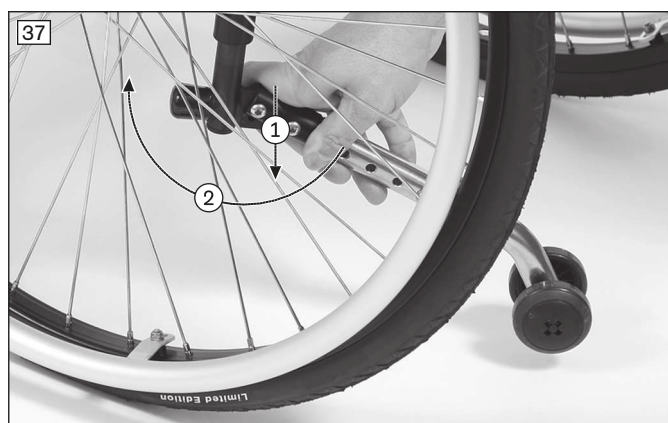
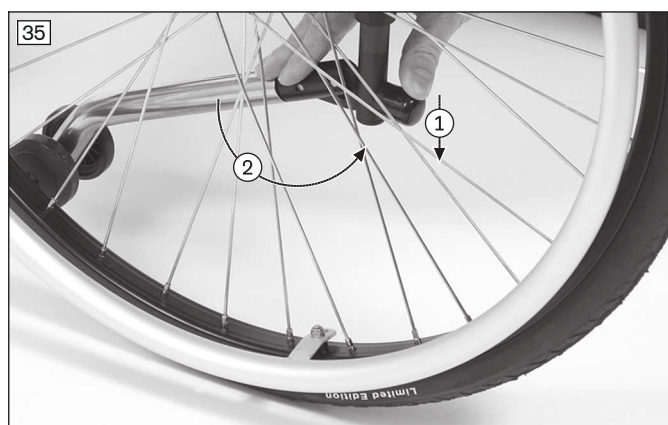

7.12.2 Tip-assist

The tip-assist makes overcoming obstacles easier for the attendant.

7.12.2.1 Using the tip-assist

For this wheelchair type, the tip-assist is integrated into the frame (see fig. 39).

- 1) At an obstacle, place one foot on the tip-assist and push down.
- 2) Slightly tip the wheelchair by simultaneously pressing down on the push handles.



7.13 Front frame

The product can be delivered with two front frame versions:

- **Standard front frame:** The wheelchair features a straight front frame without abduction (see page 6).
- **Abduction front frame:** The frame is contoured to the outside by **20 mm** on both the left and right sides (not illustrated). This makes the entry area larger.

7.14 Lap belt (seat belt)

⚠ WARNING

Using the belt system or positioning aid as a passenger restraint system in vehicles for transporting persons with reduced mobility is prohibited

Serious injuries due to improper handling of the product

- ▶ Under no circumstances may the belts and positioning aids that come with the product be used as part of a passenger restraint system in vehicles for transporting persons with reduced mobility.
- ▶ Note that the belts and positioning aids that come with the product are intended only as additional support for the user sitting in the product.

⚠ CAUTION

Incorrectly adjusted lap belt

Malpositions, illness, falling of the user due to installation/adjustment errors

- ▶ Do not modify the settings established by the qualified personnel. In case of problems with the adjustments (unsatisfactory sitting position) please contact the qualified personnel who fitted the product.
- ▶ The lap belt has to fit closely but not too tightly so the user is not injured. It should be possible to slide two fingers comfortably between the belt and thigh.
- ▶ Have the settings of the belt system checked regularly. Adjustments may be required due to the growth of the user or because of changes in the course of the disease or different clothing.

⚠ CAUTION

Improper use

Falls, user falling out due to improper use

- ▶ The lap belt must be put on when getting into the product and used at all times while using the product.
- ▶ Only open the lap belt when the user is ready to get out of the product.
- ▶ Do not leave the user unsupervised if the cognitive abilities of the user could lead to unintentional opening of the positioning system.

The lap belt (seat belt) prevents the user from slipping and supports positioning.

It is installed on the product by qualified personnel if needed and adapted to the requirements of the user.

Information about subsequent acquisition and mounting is provided by the qualified personnel that handed over the product.

Using the lap belt

- 1) Open the buckle.

- 2) Place the user in an upright, 90° seated position (if physiologically possible). Ensure that the back is up against the back support pad (if physiologically possible).
- 3) Close the buckle.
- 4) The lap belt should be at an angle of about 60° to the seat bottom. The belt strap should run across the thighs in front of the pelvic bones (see fig. 40).

Possible errors

- The lap belt is positioned above the user's pelvis in the area of the soft part of the stomach.
- The user does not sit upright in the seat.
- If the lap belt is too loose, the user can shift/slide out to the front.
- During the installation/adjustment, the lap belt is routed over parts of the seating system (e.g. over forearm supports or seat pads). This causes the lap belt to lose its retaining function.

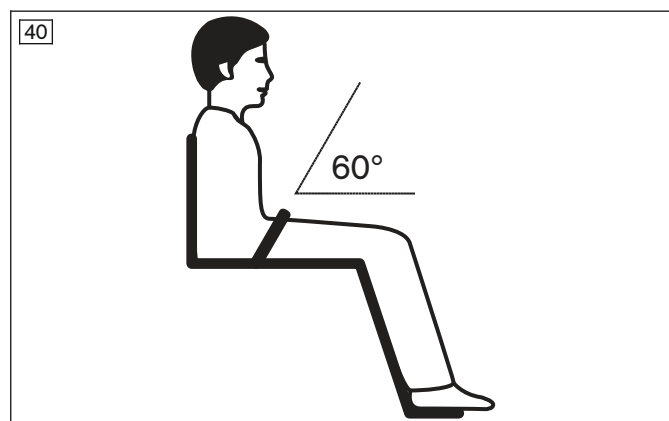

7.15 Transport wheels

⚠ CAUTION

Knee lever wheel lock when the drive wheels are removed

Risk of accident, falling due to loss of functionality of the knee lever wheel lock

- ▶ Note that a wheelchair with transport wheels can only be braked by an attendant.

⚠ CAUTION

Incorrect height setting

Risk of tipping or falling due to the sloped product setting

- ▶ Always adjust the height equally on both sides.

The transport wheels (see fig. 41) permit movement through very narrow passages (e.g. in trains or aircraft).

Transport wheels take the place of the drive wheels. In order to move, an attendant is required to push the wheelchair.

7.15.1 Using the transport wheels

- > Prior to use, verify whether the transport wheels have been set to the same height. If this is not the case: Press in the locking pin and adjust the height equally on both sides. The locking pin must engage audibly.
- 1) Remove the drive wheels.
Whenever possible, this should be done when the user is not sitting in the wheelchair. If the user is sitting in the wheelchair, proceed as follows:
 - 2) The first attendant holds the wheelchair in a stable position so that the drive wheels are relieved in turn.
 - 3) The second attendant carefully removes the first and second drive wheel one after the other.
- The wheelchair can now be pushed on the transport wheels.



7.16 Crutch holder with hook-and-loop fastening strap

The crutch holder with hook-and-loop fastening strap allows crutches to be attached to the wheelchair.



7.17 Head and neckrest

Head/neckrests or headrests make it possible to support the head in case of various severe disability indications. The head/neckrests or headrests consist of polyurethane foam and can be cleaned with mild soap and water.

The option is installed on the product by qualified personnel if needed and adapted to the requirements of the user. The user may adjust the movable blocks of the headrest according to his/her preferences.

To do so, adjust the movable blocks into the desired position and tighten the wrench bolts to fix the headrest in place.

7.18 Tray

⚠ WARNING

Product catching fire

Burns due to user error

- ▶ The product is flammable. The possibility that it may catch fire if exposed to an ignition source cannot be excluded. Therefore, the utmost caution must be exercised in the vicinity of an open flame.
- ▶ Keep away from all ignition sources.

⚠ CAUTION

Improper adjustment

Crushing or pinching due to adjustments which are too tight

- ▶ Do not pinch the user when sliding in the product.

⚠ CAUTION

Driving with objects on the tray top

Injuries due to unsecured objects

- ▶ Remove all objects from the tray top prior to travelling.

CAUTION**Improper lifting by attendants**

Tipping over, user falls due to lifting by removable components

- ▶ The product must not be lifted by the tray.

NOTICE**Overloading**

Damage to the product due to user error

- ▶ Do not load the tray with heavy objects.
- ▶ No persons may sit or lean on the tray.

The tray serves as a supporting surface during meals, when working or when playing. The clear material allows visibility of the legs and correction of the sitting posture.

Prior to use in a vehicle for transporting persons with reduced mobility, the tray has to be removed.

Attaching and removing the tray

- 1) Slide the tray onto the arm supports.
- 2) Detach the tray from the arm supports.

Always guide the tray parallel to the arm supports to avoid tilting.

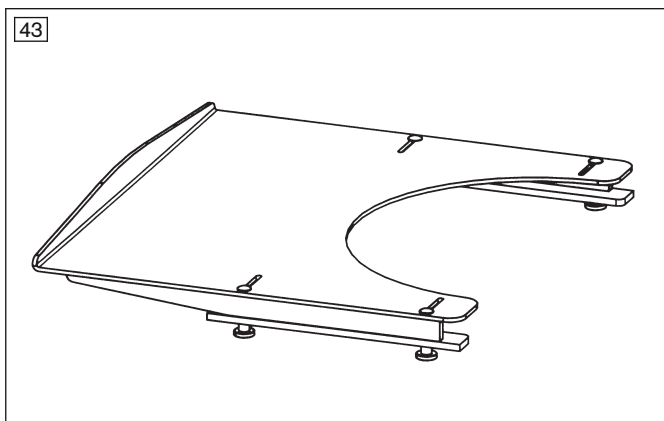
**7.19 Additional options**

The product may be equipped with additional options.

The options are firmly mounted to the product by qualified personnel or the manufacturer and are pre-adjusted by qualified personnel at delivery.

7.20 Disassembly and transport**CAUTION****Exposed pinch points**

Crushing, pinching due to incorrect handling

- ▶ When folding the wheelchair out or together, only grip by the specified components.

NOTICE**Deformation when folded**

Damage to the product, problems unfolding due to unallowable loads

- ▶ Never place heavy objects on the folded product.

INFORMATION

- ▶ When transporting the wheelchair in vehicles, fold it up and remove the wheels and leg supports if necessary.
- ▶ Follow the IATA (International Air Transport Association) rules and those of the relevant airline when transporting the wheelchair in an aircraft. Inform the airline several days before your flight. Use the SSR (special service request) codes to describe the type of limited mobility if necessary. You can for example research these on the Internet.

The wheelchair must be prepared for transport in a passenger vehicle.

- 1) Fold up the leg supports (see page 12). To make the wheelchair more handy for transportation, the leg support can also be taken off (see page 13).
- 2) **If necessary:** Detach the seat cushion from the hook-and-loop fastener.
- 3) Pull up the seat upholstery until the wheelchair folds together (see fig. 44).
- 4) Fasten the safety strap (see fig. 45).
- 5) Remove the drive wheels (see page 18).
- 6) Place the wheelchair in the vehicle.



7.21 Use in vehicles for transporting persons with reduced mobility

⚠ WARNING

Use in vehicles for transporting persons with reduced mobility

Serious injuries in case of accidents due to user error

- ▶ Always use the seats and personal restraint systems in the vehicle for transporting persons with reduced mobility first. This is the only way to ensure optimum protection of passengers in the event of an accident.
- ▶ The product may be used as a seat in a vehicle for transporting persons with reduced mobility if the safety elements provided by the manufacturer and appropriate fastening and personal restraint systems are used. For more information, please also refer to our brochure with the order number 646D158=ALL_INT.
- ▶ Never transport more than one person in the product.
- ▶ Use the product in a vehicle for transporting persons with reduced mobility only with the back support in a vertical position.
- ▶ Note the limitations regarding installed options (see page 31).

⚠ WARNING

Using the belt system or positioning aid as a passenger restraint system in vehicles for transporting persons with reduced mobility is prohibited

Serious injuries due to improper handling of the product

- ▶ Under no circumstances may the belts and positioning aids that come with the product be used as part of a passenger restraint system in vehicles for transporting persons with reduced mobility.
- ▶ Note that the belts and positioning aids that come with the product are intended only as additional support for the user sitting in the product.

The product has been tested by the manufacturer according to ISO 7176-19 and may be used as a seat in vehicles for transporting persons with reduced mobility subject to the conditions defined below.

The product must be sufficiently secured during transport in vehicles for transporting persons with reduced mobility. The illustrations that follow show an example for anchoring in a motor vehicle.

The manufacturer is not responsible for the fastening systems that are used. Ensure that only fastening systems that meet the applicable legal requirements and are designed for the overall weight of the product including the user are used.

The transport weight of the person to be transported in a vehicle for transporting persons with reduced mobility corresponds to the maximum permissible user weight (see page 37).

7.21.1 Required accessories

Four belt loops are necessary in order to use the product as a transport seat in a vehicle for transporting persons with reduced mobility (tested according to ISO 10542-1 or comparable test standards). The qualified personnel who fitted the wheelchair can provide more information.

Required materials

- 4 belt loops (e.g. from the manufacturers Q'STRAIT or BraunAbility, tested according to ISO 10542-1)

7.21.2 Using the product in a vehicle

⚠ WARNING

Positioning in vehicles for transporting persons with reduced mobility

Serious injuries in case of accidents due to user error

- ▶ Positioning of the product in vehicles for transporting persons with reduced mobility may only be performed by the qualified personnel.
- ▶ The product must always face forwards when it is used as a seat in a vehicle for transporting persons with reduced mobility.
- ▶ Instruct the qualified personnel regarding the mounting points on your product described below.

⚠ WARNING

Inadequate transportation safety

Loss of safe restraint due to failure to observe transportation instructions

- ▶ Observe the following instructions for correct transport safety in the vehicle for transporting persons with reduced mobility.
- ▶ If necessary, instruct the qualified personnel on the following information.

Securing the product in the vehicle for transporting persons with reduced mobility

The wheelchair is secured in the vehicle for transporting persons with reduced mobility with the help of four belt loops, to which the vehicle-side wheelchair restraint belts are attached.

The fixation points of the belt loops are marked with stickers. These stickers show where the user has to pass the belt loops around the frame tube:

- The stickers that label the front fixation points are found on the front frame tube on each side (see fig. 46, item 1).
- The stickers that label the rear fixation points are found on the rear frame tube on each side (see fig. 47, item 1).



Attaching the belt loops

- 1) Position the product in the vehicle for transporting persons with reduced mobility. For more information, please also refer to our brochure with the order number 646D158=ALL_INT.
- 2) Engage the two wheel locks (see page 20).
- 3) **Front fixation points:** Attach one belt loop around each of the frame tubes on the left and right of the front frame, wrapping them around the frame tubes at the marked position once or twice depending on the length (see fig. 48, item 1).
- 4) Engage the hook of the respective vehicle-side wheelchair restraint belt in the belt loop (see fig. 48, item 2).

- 5) **Rear fixation points:** Attach one belt loop around each of the frame tubes on the left and right, wrapping them around the frame tubes at the marked position (see fig. 49, item 1).
- 6) Engage the hook of the respective vehicle-side wheelchair restraint belt in the belt loop (see fig. 49, item 2).
- 7) Tighten the vehicle-side wheelchair restraint belts at the front and rear as firmly as possible.
→ The product showing the correct positioning of the attachment straps (see fig. 50).

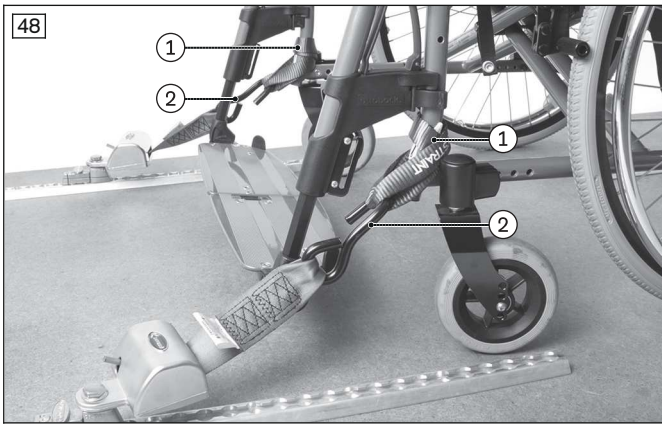

Information on correct transport safety of the user in the vehicle for transporting persons with reduced mobility

- Using the personal restraint system of the vehicle for transporting persons with reduced mobility is required. Attaching personal restraint systems of the vehicle for transporting persons with reduced mobility to the wheelchair is not permitted. The 3-point restraint has to be realised entirely on the vehicle:
 - The lap belt of the personal restraint system is usually attached by the qualified personnel to the left and right sides respectively on the mounting point/pin of the rear lashing straps (wheelchair restraint belts on the vehicle bottom).
 - The shoulder belt of the personal restraint system is usually mounted on the vehicle pillar and is attached by the qualified personnel to the corresponding mounting point/pin provided on the lap belt.
- The straps of the personal restraint system must always be routed close to the user's body. The straps must not be routed over the side panels and wheels (see fig. 51 item 2).
- The shoulder belt must always be routed over the user's shoulder (see fig. 51, item 1).
- The belt strap must not be twisted on the user's body.

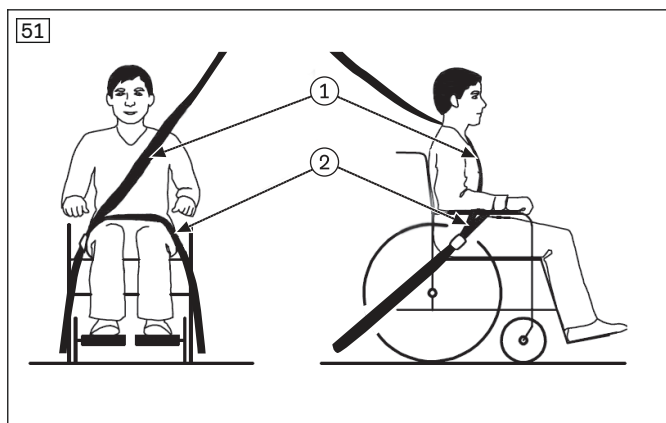

Placement of the personal restraint system integrated in the vehicle for transporting persons with reduced mobility

- 1) Pull each end of the restraint lap belt from the inner side of the seat through to the outside (see fig. 52).
- 2) Engage the ends of the restraint lap belt on the mounting point/pin of the rear lashing straps on the left and right sides respectively (see fig. 53).
- 3) Secure the shoulder harness on the mounting point/pin provided on the lap belt (not illustrated).
 - The restraint lap belt is pulled through and fastened.
 - The belt runs between the side panel and seat cushion on each side.

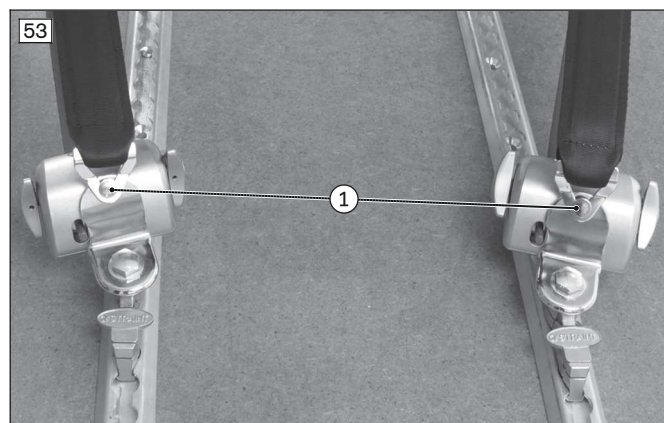

7.21.3 Restrictions for use

Equipment versions and options not approved for transportation in a vehicle for transporting persons with reduced mobility

⚠ WARNING

Improper use in vehicles for transporting persons with reduced mobility

Risk of serious injury when using the product as a seat

- ▶ The manufacturer has **not** approved wheelchairs with the equipment versions and options listed below for use as a seat in vehicles for transporting persons with reduced mobility.
- ▶ In vehicles for transporting persons with reduced mobility, only use the seats installed in the vehicle with the corresponding personal restraint systems.
- ▶ Please contact the qualified personnel for up-to-day information regarding transportation in a vehicle for transporting persons with reduced mobility.

Option

Crutch holder with tip-assist, right/left

Angle-adjustable back support

Back support height < 400 mm

Drive wheels 26"

Options that restrict use in vehicles for transporting persons with reduced mobility

WARNING

Using the product with certain settings and/or installed options

Severe injury in case of accidents due to options coming loose

- ▶ Before using the product as a seat in a vehicle for transporting persons with reduced mobility, remove options that need to be taken off for safe transportation in such a vehicle. Please observe the following table.
- ▶ Stow all removed options securely in the vehicle.
- ▶ Please note that certain settings on the product exclude the use of the product in a vehicle for transporting persons with reduced mobility.

Option ¹⁾	Remove the option including mounting accessories ²⁾	Observe notice regarding the option	Observe the instructions for use
Tray	X		
Transport wheel		X ³⁾	
Lap belt		X ⁴⁾	
Spoke protectors	X		
Add-on drive ⁵⁾	X		X ⁶⁾
Custom fabrication versions on customer request			X ⁷⁾

¹⁾ Not all of the options named are installed on all products.

²⁾ Applies to all parts that can be removed without the use of tools.

³⁾ Transport wheels can remain on the wheelchair with installed drive wheels during transportation in a vehicle for transporting persons with reduced mobility.

⁴⁾ The lap belt can be used to position the passenger during transportation. Using the personal restraint system is nevertheless required.

⁵⁾ Add-on drives have not been tested by Ottobock and may not be used on wheelchairs in vehicles for transporting persons with reduced mobility.

⁶⁾ If the manufacturer of the add-on drive permits use in vehicles for transporting persons with reduced mobility, the instructions for use of the add-on drive must be observed.

⁷⁾ Note possible exclusions in the additional documentation included on delivery of the custom fabrication.

7.22 Care

CAUTION

Lack of or improper cleaning

Health hazard due to infections, damage to the product due to user error

- ▶ Clean the product at regular intervals.
- ▶ Check the driving behaviour of the product after cleaning it.

INFORMATION

Take note of the washing and care instructions on the sewn-in labels on the fabric covers and other textile parts of the product.

7.22.1 Cleaning

Clean the product regularly depending on the degree of soiling and frequency of use, **at least 1x per month**:

7.22.1.1 Cleaning by hand

- 1) Clean the padding and upholstery with warm water and a mild detergent.
- 2) Remove any spots with a sponge or a soft brush.
- 3) Rinse with clear water and let the components dry.

Important information on cleaning

- Clean plastic parts, frame parts and the chassis and wheels with a mild cleaner and a damp cloth. Dry thoroughly afterwards.
- Do not use any aggressive cleaners, solvents or hard brushes etc.

- Do not clean the product with a pressure washer or a jet of water. The penetration of water can cause corrosion.

7.22.1.2 Cleaning the seat cushion

Standard seat cushion

- ▶ Clean the seat cushion according to the attached care label.

Seat cushion with foam core

- 1) Open the zip and remove the foam core (see fig. 54).
- 2) Clean the cover according to the attached care label.
- 3) Hand wash all foam parts at **40 °C** using a mild, environmentally friendly detergent. Allow to air dry.
- 4) Reinsert the foam core with proper alignment. Close the zip.



Important information on cleaning

- For more information on cleaning seat cushions, see the care instructions on the product or the supplied instructions for use.

7.22.1.3 Cleaning belts/straps

Cleaning a belt system with metal closure

INFORMATION

Observe the washing recommendations on the product and the information in the corresponding instructions for use provided for the product.

- Straps with metal closures **may not be washed in the washing machine** as the penetration of water could cause corrosion and subsequent malfunctions.
- Clean the belt straps by gently dabbing them with warm soapy water (with some disinfectant) or carefully wipe with a dry, clean, absorbent cloth.

Cleaning a belt system with plastic closure

- Depending on the model, belts/straps with plastic buckles can be washed in the washing machine between **40 °C** and **60 °C**.
- **Recommendation:** Use a laundry bag or net and mild detergent.
- Alternatively, the belt straps can be cleaned by gently dabbing them with warm soapy water (with some disinfectant) or carefully wiped with a dry, clean, absorbent cloth.

Additional cleaning instructions

- Allow the belts to air dry. Ensure that the belts and pads are completely dry before installation.
- Do not expose the belts to direct heat (e.g. sunshine, stove or radiator).
- Do not iron or bleach the belts.

7.22.2 Disinfection

- 1) Thoroughly clean the pads and handles before disinfecting.
- 2) Wipe all parts of the wheelchair with a disinfectant.

Important information about disinfecting

- If the product is used by more than one person, using a conventional disinfectant is required.
- Only use colourless water-based disinfectants. Follow the instructions for use provided by the disinfectant manufacturer.

8 Maintenance and repair

8.1 Maintenance

⚠ WARNING

Insufficient maintenance
 Severe user injuries, damage to the product due to failure to observe maintenance intervals

- ▶ Only carry out the maintenance tasks described in this section. All other maintenance and service tasks may only be carried out by qualified personnel.
- ▶ The functionality and operating safety of the product must be verified and a service performed at least **once per year**.
- ▶ For users with a changing anatomy (for example body dimensions, weight) or users with a changing clinical picture, have the product inspected, adjusted and serviced at least **once every six months**.

⚠ WARNING

Improper maintenance
 Severe injury of the user due to screw connections coming loose

- ▶ Check the tightness of the screw connections at regular intervals.
- ▶ Contact the qualified personnel promptly if defects are noted.

- The function of the product should be checked **before each use**.
- The product may not be used if defects are noted, e.g. loose, worn, bent or damaged components, frame cracks, broken frame components. This applies in particular in case of instability of the product or changed driving characteristics as well as problems with the user's sitting position or the stability of the seat. Inform the qualified personnel promptly to rectify defects.
- Some maintenance tasks can be carried out to a certain extent by the user at home (see the sections "Maintenance intervals" and "Maintenance tasks").
- Failure to maintain the product can lead to injuries for the user of the product.

8.1.1 Maintenance intervals

The functions described below must be checked by the user or an attendant at the specified intervals:

Inspection task	Before each use	Monthly	Quarterly
Functional test of the wheel locks	X		
Sagging of the seat or back support upholstery		X	
Stability of the leg supports		X	
Visual inspection of wear and tear parts (e.g., tyres, bearings)		X	
Soiling of bearings		X	
Damage to the handrim		X	
Air pressure (see tyre sidewall for specifications)		X	
Wear and tear of the folding mechanism		X	
Check of the spoke tension on the drive wheels			X
Check of all screw connections			X
Check the legibility of all labels and markings on the product		X	

8.1.2 Maintenance tasks

To ensure smooth operation at all times, users or attendants with some technical skills can maintain some parts of the product:

- Screw connections must be periodically checked for tightness, especially during the initial period of use or after adjustments have been made to the wheelchair. If a screw connection loosens repeatedly, contact the qualified personnel promptly.

- Particles of dirt and hair accumulate on the caster wheel axle and threaded axle of the caster fork over time. This makes the steering stiffer. Regularly remove dirt and oil the axles. See the section “Approach in case of stiffness”.
- The drive wheels are equipped with a quick-release axle system as standard equipment. To keep this system operational, ensure that no dirt adheres to the quick-release axle or receiver bushing. Periodically lubricate the quick-release axle lightly with thin, resin-free oil (sewing machine oil).
- If the wheelchair becomes wet, it should be rubbed dry again.

8.2 Repair

⚠ WARNING

Prohibited repairs

Severe user injuries, damage to the product due to adjustment and installation errors

- ▶ Only carry out the repairs described in this section. All other repairs may only be carried out by the qualified personnel.

8.2.1 Inner tube, rim tape and tyre replacement

⚠ CAUTION

Improper tyre replacement

Injuries to the user due to incorrect installation, product damage

- ▶ No person is permitted to sit in the wheelchair during tyre replacement
- ▶ Before removing a wheel, support the product so it cannot tip over.
- ▶ Always replace the tyres in pairs. Two differently worn tyres affect the directional stability of the wheelchair.

INFORMATION

When driving outdoors, always carry a repair kit and tyre pump (when using pneumatic tyres) in case of emergency.

Suitable tyre pumps are listed on the order form and are supplied with the product. An alternative is tyre foam, which fills your tyre and then hardens (available from bicycle shops, etc.).

Repairing flat tyres requires only the necessary tools, and users may change tyres themselves if they wish:

Removal and preparing for installation

- 1) Carefully remove the tyre from the rim using appropriate assembly tools.
INFORMATION: Take care not to damage the rim or the inner tube.
- 2) Unscrew the valve nut from the valve and remove the tube.
- 3) Repair the tube according to the directions in the repair kit or replace it with a new tube.
- 4) Before fitting the tyre again, inspect the rim bed and tyre inner wall for foreign objects. Lift the rim band if necessary.
- 5) Before installing the tube, check that the rim band is in proper condition. The rim band protects the tube from being damaged by the ends of the spokes.



Replacing the rim band (only when necessary)

- 1) If the rim band needs to be replaced, remove it from the rim.

- 2) Install the new rim band on the inside of the rim, making sure the valve opening is in the right position.
- 3) Glue the rim band in place if this is intended. Ensure that all spoke ends are covered.

Installing the tube and tyre

- 1) Behind the valve, push one side of the tyre over the edge of the rim.
- 2) Slightly inflate the tube until it starts to assume its round shape.
- 3) Unscrew the valve nut from the tube and push the valve through the valve opening in the rim.
- 4) Insert the tube into the tyre.
- 5) Mount the other side of the tyre on the rim, starting from the position across from the valve. Ensure that the tube is not pinched between the tyre and rim during this process.



Inflating the tube

- 1) Ensure that the valve is positioned perpendicularly so the tube and tyre are properly positioned in the region of the valve.
- 2) Firmly screw on the valve nut.
- 3) Inflate the tube so that the tyre can still be pressed in easily with your thumb.
INFORMATION: If the circumferential lines on the two sides of the tyre are both at an even distance from the rim, the tyre is centred. If not, let some air out and realign the tyre.
- 4) Inflate the tube to the maximum pressure specified by the tyre manufacturer (see information printed on the tyre sidewall).
- 5) Firmly screw the valve cap onto the valve.

9 Disposal

9.1 Disposal information

Return the product to the qualified personnel for disposal.

All components of the product must be disposed of properly in accordance with the respective national environmental regulations.

10 Legal information

All legal conditions are subject to the respective national laws of the country of use and may vary accordingly.

10.1 Liability

The manufacturer will only assume liability if the product is used in accordance with the descriptions and instructions provided in this document. The manufacturer will not assume liability for damage caused by disregarding the information in this document, particularly due to improper use or unauthorised modification of the product.

10.2 Warranty

Further information on the warranty terms and conditions is available from the qualified personnel that adapted this product or the manufacturer's service department.

10.3 Lifetime

Expected lifetime: **4 years**

The design, manufacturing and requirements for the intended use of the product are based on the expected life-time. These also include the requirements for maintenance, ensuring effectiveness and the safety of the product. Failure to observe the manufacturer's specifications and service intervals and using the product beyond the specified expected lifetime leads to increased residual risk.

11 Technical data

INFORMATION

- ▶ Much of the technical data below is given in mm. Please note that product settings – unless otherwise specified – cannot be adjusted in the mm range but only in increments of approx. **0.5 cm** or **1 cm**.
- ▶ Note that the values achieved during adjustment may deviate from the values specified below. The deviation can be **±10 mm** and **±2°**.

INFORMATION

- ▶ Some of the measurements indicated below are values that were theoretically determined.
- ▶ Note that not all adjustment possibilities can be used with all product versions. Furthermore, the adjustment combinations are limited by the compact frame geometry.
- ▶ Technical changes and tolerances are reserved by the manufacturer.

	Avantgarde XXL 2
Max. load [kg]	180
Transport weights [kg] ¹⁾	Frame: from 11.3 24" drive wheel: from 1.3 (including quick-release axle)
Min. tyre pressure [bar] ²⁾	7
Permissible tyre type – drive wheels	Pneumatic tyres, PU tyres
Permissible tyre type – caster wheels	Solid rubber, pneumatic tyres, soft caster
Maximum permissible inclination [°]/[%] ³⁾⁴⁾⁵⁾	7 / 12.3

¹⁾ The specified weights vary according to the selected options and model.

²⁾ Varies according to tyre option; see the marking on the tyre wall.

³⁾ Also applies for parking with wheel lock engaged.

⁴⁾ Applies to all directions (upwards, downwards, sideways).

⁵⁾ In accordance with ISO 7176-1.

Additional information

Avantgarde XXL 2	Minimum	Maximum
Weight [kg] ¹⁾	14 ²⁾	17 ²⁾
Overall length with leg supports [mm]	790	1140
Overall width [mm]	695	850
Folding size, length with leg supports [mm]	790	1140
Folding size, width [mm]	320	380
Folding size, height [mm]	700	1053
Seat bottom angle (difference between front/rear seat height) [°]	approx. 15	
Effective seat depth [mm]	400	560
Effective seat width [mm]	460	620
Front seat height [mm]	460	530
Rear seat height [mm]	410	530
Back support angle (in reference to perpendicular to the seat bottom) [°]	-9	+15
Back support height [mm]	250	500
Distance from leg support to seat [mm]	320	550 ³⁾
Distance from arm support to seat [mm]	245	340

Avantgarde XXL 2	Minimum	Maximum
Angle from leg support to seat bottom [°]	Angle-adjustable (as needed)	
Handrim diameter [mm]	470	560
Minimum turning radius [mm] ¹⁾	550	740

¹⁾ In accordance with ISO 7176-5.

²⁾ The specified weights vary according to the selected options and variant.

³⁾ Restriction due to normative ground clearance requirements; individually larger by customer request, maximum depending on seat height, foot plate and foot plate angle setting.

Ambient conditions

Temperatures and relative humidity	
Temperature during use [°C (°F)]	-10 to +40 (14 to 104)
Transport and storage temperature [°C (°F)]	-10 to +40 (14 to 104)
Relative humidity [%]	45 to 85; non-condensing

12 Appendices

12.1 Threshold values for wheelchairs transportable by train

INFORMATION

- ▶ The products in this series fully satisfy the minimum technical requirements of Regulation (EU) No. 1300/2014 regarding train accessibility for people with disabilities. However, not all versions can comply with all threshold values due to different settings.
- ▶ With the help of the table that follows, you or the qualified personnel can take measurements and verify whether the specific product in question meets the threshold values.

Characteristic	Threshold value (according to Regulation (EU) No. 1300/2014)
Length [mm]	1200 (plus 50 mm for the feet)
Width [mm]	700 (plus 50 mm on each side for the hands when moving)
Smallest wheels ["]	approx. 3 or greater (according to the directive, the smallest wheel must be able to overcome a gap measuring 75 mm horizontally and 50 mm vertically)
Height [mm]	max. 1375; including a 1.84 m large male wheelchair user (95th percentile)
Turning radius [mm]	1500
Maximum weight [kg]	200 (for wheelchair and user, including any baggage)
Maximum obstacle height that can be overcome [mm]	50
Ground clearance [mm]	60 (at an upward slope angle of 10°, ground clearance must measure at least 60 mm under the foot support for going forward at the end of the slope)
Maximum inclination angle on which the wheelchair will remain stable [°]	6 (dynamic stability in all directions) 9 (static stability in all directions, also when wheel lock engaged)

Ihr Fachhändler | Your specialist dealer



Otto Bock Mobility Solutions GmbH
Lindenstraße 13 · 07426 Königsee/Germany
www.ottobock.com

