

17B203=* E-MAG Active

EN Instructions for use (qualified personnel)	4
--	---

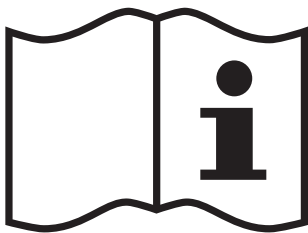

**Order your
free printed copy**



order-ifu@ottobock.com

Document: 647G1165 Version: 08

<https://product-documents.ottobock.com/IFU/INT/17B203/647G1165/08/O/S/F>

- DE** | Weisen Sie den Benutzer in den sicheren Gebrauch des Produkts ein.
Weitere Sprachen dieser Gebrauchsanweisung sind online verfügbar oder können kostenlos als gedrucktes Exemplar bestellt werden (siehe Seite 2).
- EN** | Instruct the user how to use the product safely.
These instructions for use are available in additional languages online or can be ordered as a printed copy free of charge (see page 2).
- FR** | Apprendre à l'utilisateur comment utiliser le produit en toute sécurité.
D'autres langues de cette notice d'utilisation sont disponibles en ligne ou peuvent être commandées gratuitement en format papier (voir page 2).
- IT** | Istruire l'utente sull'uso sicuro del prodotto.
Altre lingue delle presenti istruzioni per l'uso sono disponibili online o possono essere ordinate gratuitamente su supporto cartaceo (vedere pagina 2).
- ES** | Explique al usuario cómo utilizar el producto de forma segura.
Encontrará estas instrucciones de uso en otros idiomas en línea. También puede solicitarlo gratuitamente como ejemplar impreso (véase la página 2).
- PT** | Instrua o usuário sobre a utilização segura do produto.
Outros idiomas destas instruções de uso estão disponíveis online ou podem ser solicitados gratuitamente como um exemplar impresso (veja a página 2).
- NL** | Leer de gebruiker hoe hij/zij veilig met het product moet omgaan.
Andere talen van deze gebruiksaanwijzing zijn online beschikbaar of kunnen gratis in gedrukte vorm worden besteld (zie pagina 2).
- SV** | Instruera användaren i hur produkten används på ett säkert sätt.
Den här bruksanvisningen finns tillgänglig på andra språk online och kan beställas kostnadsfritt i tryckt form (se sidan 2).

-
- DA** | Instruér brugeren i, hvordan man produktet anvendes på sikker vis.
Denne brugsanvisning er tilgængelig på yderligere sprog online eller kan bestilles gratis som et trykt eksemplar (se side 2).
- NO** | Instruer brukeren i sikker bruk av produktet.
Flere språk for denne bruksanvisningen er tilgjengelige på nett, eller de kan bestilles som utskrevet eksemplar (se side 2).
- FI** | Perehdytä käyttäjä tuotteen turvalliseen käyttöön.
Tämän käyttöohjeen muut kielet ovat saatavilla online tai niitä voi tilata maksutta painettuna versiona (katso sivu 2).
- CS** | Poučte uživatele ohledně bezpečného používání produktu.
Další jazykové verze tohoto návodu k použití jsou k dispozici online nebo je lze zdarma objednat v tištěné podobě (viz str. 2).
- SK** | Používateľa zaučte do bezpečného zaobchádzania s výrobkom.
Ďalšie jazykové mutácie tohto návodu na použitie sú dostupné online alebo si možno bezplatne objednať ich tlačenu verziu (pozri strana 2).
- TR** | Ürünün güvenle kullanımı konusunda kullanıcıyı bilgilendirin.
Bu kullanım kılavuzundaki diğer diller online olarak mevcuttur veya ücretsiz basılı kopya olarak sipariş verilebilir (bkz. sayfa 2).
- RU** | Проинструктируйте пользователя на предмет безопасного применения изделия.
Текст настоящего руководства по применению на других языках доступен онлайн или может быть заказан бесплатно в печатном виде (см. стр. 2).
- ZH** | 就产品的安全使用给予用户指导。
使用说明书的其他语言版本可在线获取，也可免费订购印刷版（参见第 2 页）。

Basic UDI-DI: 4032767000000017B203XL

1 Foreword

INFORMATION

Date of last update: 2023-09-29

- ▶ Please read this document carefully before using the product and observe the safety notices.
- ▶ Instruct the user in the safe use of the product.
- ▶ Please contact the manufacturer if you have questions about the product or in case of problems.
- ▶ Report each serious incident in connection with the product, in particular a worsening of the state of health, to the manufacturer and to the relevant authority in your country.
- ▶ Please keep this document for your records.

These instructions for use provide important information on the processing of the 17B203 E-MAG Active orthotic knee joint.

A quick start guide is available for the user, providing an overview of the E-MAG Active functions.

Provide the user with the instructions for use and the quick start guide upon delivery of the orthosis, and point out the semi-annual maintenance intervals.

2 Product description

2.1 Available sizes

INFORMATION

The subsequent conversion of the E-MAG 5° flexion lower part to 7.5° may only be completed by an authorised Ottobock Service Centre.

Article number	Material	Pre-flexion	17B206 medial support	Max. body weight
17B203=L/R, 17B203=L/R-7.5	Steel	5° and 7.5°	Without medial support	Up to 85 kg
17B203=L/R, 17B203=L/R-7.5	Steel	5° and 7.5°	With medial support	Up to 100 kg

2.2 Function/design

Function

The E-MAG Active is an orthotic joint with stance phase control which offers the user a free swing phase and locks the orthotic joint for the stance phase prior to heel strike.

The E-MAG Active features an electronic lock that is released during toe-off, allowing the user to swing the paralysed leg in a physiological manner. Prior to heel strike, the orthotic joint locks in the extended position so the user can step down safely.

The E-MAG Active has an additional locking function (PreLock) that is activated at 15° flexion. This secures the patient even before the actual swing phase ends. The orthotic joint is then fully locked when it reaches the extension stop.

Design

The bushing (radial bearing) and axial washer (axial bearing) are made of maintenance-free plastic. The lock wedge is electronically controlled via an electromagnet. The electronic control unit consists of a gyroscope and 2D acceleration sensors to record the gait phase. It measures the position while the user is walking and unlocks the orthotic joint prior to toe-off and then locks it again in the extended position prior to heel strike.

The open insertion zones serve to attach the lamination bars. The electronic components are designed to be replaced by a technician. The battery can be removed from the battery receptacle on the orthosis and charged in the charger. The charger has two ports so two batteries can be charged simultaneously.

2.3 Components/design

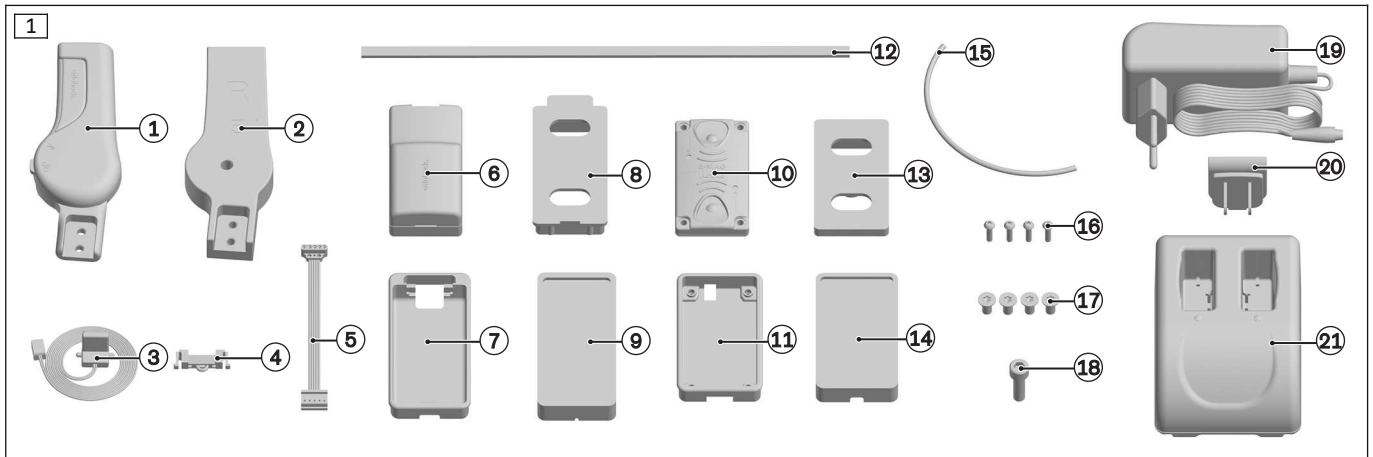

Scope of delivery (see fig. 1)

Item	Piece(s)	Designation	Article number
1	1	Orthotic joint	17B203*
2	1	Lamination dummy	317X203*
3	1	Battery cable	317E20
4	1	Ratchet unit	317R20
5	1	Electronics cable	31E2
6	2	Battery	317B20
	1	Battery receptacle set, consisting of: Item 7 Battery receptacle Item 8 Dummy for battery receptacle Item 9 Dummy for battery	317Z21
10	1	Electronics	317B3
12	1	Cable dummy	30Y140
	1	Electronic frame set, consisting of: Item 11 Electronics receptacle Item 13 Dummy for receptacle Item 14 Dummy for electronics	317Z13
15	1	Perlon cable	21A45*
16	4	Oval head screws	501S72
17	4	Screws	501S137=M5x10
18	1	Slotted oval head screw	501T128=M6x20
	1	Battery charger, consisting of: Item 19 Power supply unit Item 20 US plug Item 21 Charging cradle	317L20
Not illustrated	1	E-MAG Active instructions for use, qualified personnel	647G1165
Not illustrated	1	E-MAG Active instructions for use, users	647H648
Not illustrated	1	Battery charger instructions for use	647G310
Not illustrated	1	Instructions for use for rechargeable battery	647G309
Not illustrated	1	Quick start guide – E-MAG Active	646H17
Not illustrated	1	Orthotic Passport	646H9

Scope of delivery (see fig. 1)			
Item	Piece(s)	Designation	Article number
Not illustrated	1	Support addresses	647G339

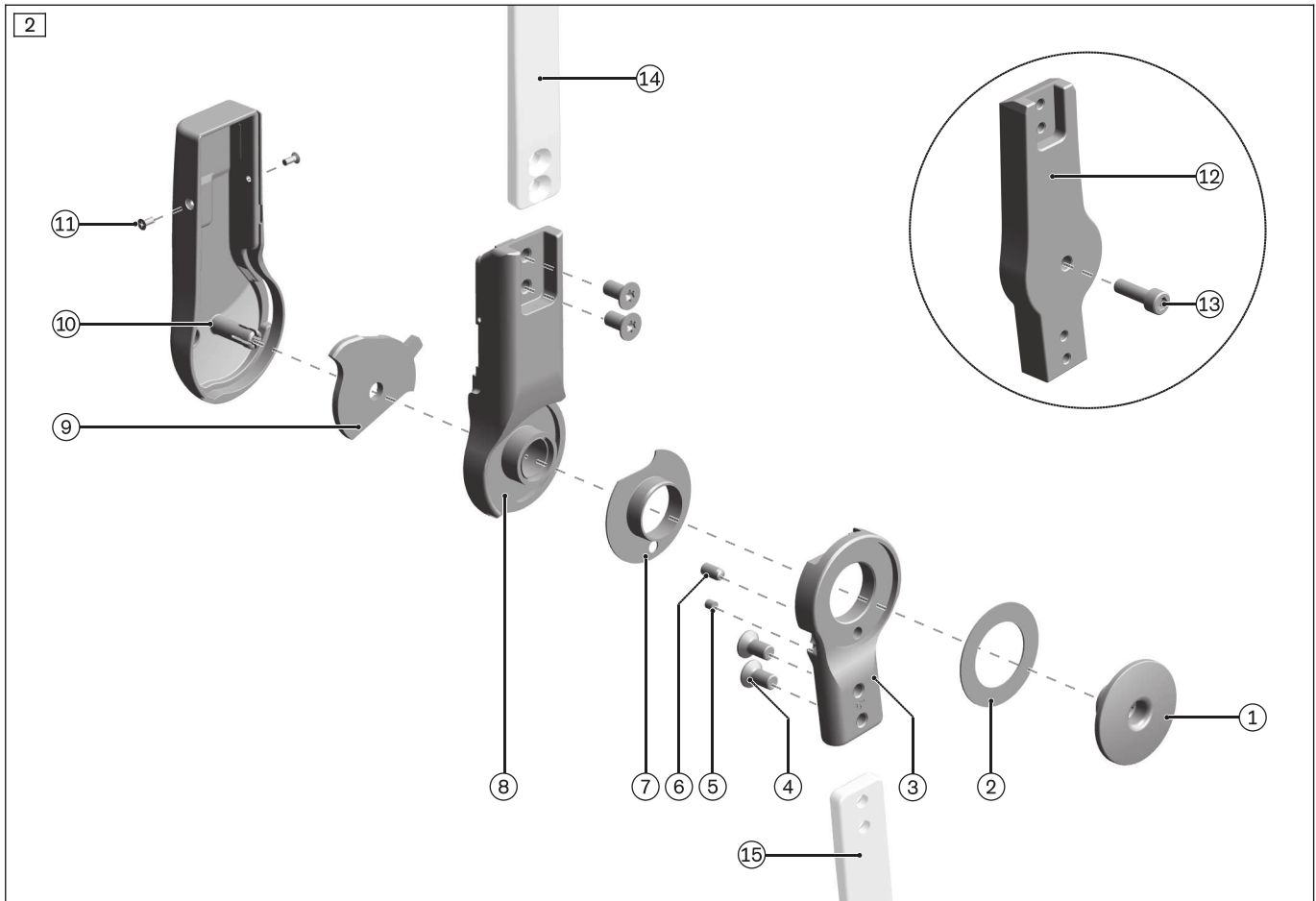

Scope of delivery (see fig. 2)			
Item	Piece(s)	Designation	Article number
1	1	Joint screw	30Y112
2	1	Axial washer	17BS203
3	1	Lower joint section	30U134=*
4	4	Countersunk screws	501S137=M5x10
5	1	Stop bumpers	617G28=3-9
6	1	Cylinder pin	506A8=4x8
7	1	Collar bushing	30Y295=*
8	1	Upper joint section	30X96=*
9	1	Unlocking mechanism	30Y353=*
10	1	Cover	30Y440=*
11	1	Phillips countersunk screws	501S21=M2x5
12	1	Lamination dummy	30Y297=*
13	1	Cap screw	501T28=M6x20

Not included in scope of delivery			
Item	Piece(s)	Designation	Article number
14	1	Lamination bar	17LS3=16, 17LS3=16-T
15	1	Lamination bar	17LS3=16, 17LS3=16-T
Not illustrated	1	Side bar	17LV3=16, 17LV3=L/R-16

3 Intended use

3.1 Indications for use

The product is intended **exclusively** for orthotic treatment of the lower limbs, for dynamic knee-ankle-foot orthoses and knee orthoses with a free swing phase and locked stance phase. Ottobock recommends using the lamination bars for the lamination and prepreg technique and side bars for the thermoplastic technique.

3.2 Indications

INFORMATION

To ensure optimal functionality of the orthosis, the patient must generate a knee extension moment before heel lift-off and also at heel impact.

Partial or total paralysis of the leg muscles.

Indications must be determined by the physician.

Ottobock recommends the 646A214 "Therapeutic Application and Gait Training" brochure.

3.3 Contraindications

Contraindications:

- Knee flexion contractures in excess of 15° that prevent the knee joint lock from being relieved
- Hip flexion contractures
- Uncontrollable spasticity
- Ischial support
- Non-physiological deviation in the frontal plane

3.4 Lifetime

The product is designed for a lifetime of **3 years** when used as intended and assembled professionally.

3.5 Qualification

Patients may be fitted with the product only by trained qualified personnel. The qualified personnel must be familiar with the handling of the various techniques, materials, machines and tools.

3.6 Combination possibilities

The 17B203* E-MAG Active orthotic joint can be combined with the medial support 17B206*.

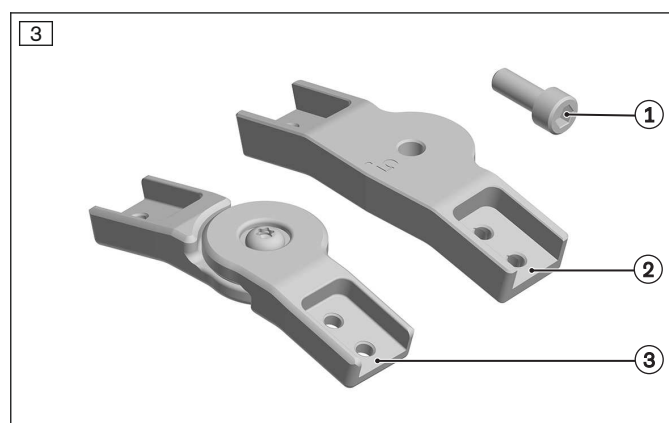

1. Slotted oval head screw for lamination dummy 501T28=M6x16
2. 317X206, 317X206=7.5 Lamination dummy for medial support in 5 or 7.5° (not illustrated)
3. 17B206, 17B206=7.5 Medial support

4 Safety

4.1 Explanation of warning symbols

CAUTION Warning regarding possible risks of accident or injury.

NOTICE Warning regarding possible technical damage.

4.2 Safety instructions

CAUTION

Risk of falling due to improper use

Provide your patient with precise instructions on the operation and use of the E-MAG Active. Be sure to inform your patient that, in case of improper use, the joint cannot release prior to toe-off or the swing phase, or cannot lock prior to heel strike. Also inform your patient of the PreLock function.

CAUTION

Mechanical damage to the product

Injuries due to changes in or loss of functionality

- ▶ Use caution when working with the product.
- ▶ Check the product for proper function and readiness for use.
- ▶ In case of changes in or loss of functionality, discontinue use of the product and have it checked by authorised, qualified personnel.

CAUTION

Risk of injury due to the use of unapproved components or spare parts

Components and spare parts that have not been authorised by the manufacturer may break. Only use components and spare parts approved by the manufacturer for installation and service.

CAUTION

Explosion hazard

Do not throw the battery into fire. Never expose it to heat. Avoid direct sunlight. Please pass this information on to your patient.

CAUTION

Excessive strain on load-bearing components

Injuries due to changes in or loss of functionality

- ▶ Only use the product for the defined area of application.
- ▶ If the product has been exposed to extreme strain (e.g. due to falling), take any necessary measures (e.g. repair, replacement, inspection by the manufacturer's customer service etc.).

CAUTION

Risk of injury due to system joint bars coming loose

Secure the countersunk head screws for attaching the 17LS3=16, 17LS3=16-T lamination bars with a tightening torque of 7 Nm using 646K13 Loctite 241.

CAUTION

Risk of pinching

Ensure freedom of movement during flexion. Do not allow sockets to overlap. The knee joint has a maximum flexion angle of **140°**.

CAUTION

Risk of falling due to incorrect calibration

During auto-calibration, proceed according to the prescribed steps in order to avoid accidentally triggering the joint.

CAUTION

Risk of falling due to improper operation of the service buttons

You must inform the patient that the service buttons must not be activated or manipulated.

⚠ CAUTION**Risk of injury during fitting**

We recommend fabricating a trial orthosis in order to verify the functionality and fit before the final orthosis is constructed. Patient suitability can also be verified by following this process. Ensure that the patient is standing securely during this process in order to eliminate the risk of falling. Carry out the fittings between parallel bars.

⚠ CAUTION**Risk of injury due to incorrect patient selection**

In the selection of patients, ensure that the patient can fully extend the knee during heel lift-off and heel strike.

⚠ CAUTION**Incorrect alignment, assembly or adjustment**

Risk of injury due to change in or loss of functionality

- ▶ Assembly, adjustment and maintenance operations may only be completed by qualified personnel.
- ▶ Observe the alignment, assembly and adjustment instructions.

⚠ CAUTION**Exposure of the product to unsuitable environmental conditions**

Patient injury, damage, brittleness or destruction due to improper handling

- ▶ Do not expose the product to condensing ambient humidity or liquids.
- ▶ Do not expose the product to abrasive substances (e.g. sand, dust).
- ▶ Do not expose the product to temperatures below -10 °C (14 °F) or above +60 °C (140 °F) (e.g. sauna, excessive sunlight, drying on a radiator).

⚠ CAUTION**Improper handling**

Risk of falling due to accidentally opening or engaging the lock

- ▶ Before placing weight on the orthosis, verify that the lock is in the desired position.
- ▶ Avoid accidentally opening or engaging the lock.
- ▶ Instruct the patient in the correct handling of the orthotic joints.

NOTICE**Thermal overloading of the orthosis joint**

Damage to the bearing washers due to improper thermal treatment, loss of orthosis joint movement

- ▶ Do not carry out any heat treatment.
- ▶ Check the function of the orthosis joint.
- ▶ Replace damaged bearing washers.

⚠ CAUTION**Knee not fully extended at heel strike**

Risk of injury due to unlocked orthosis joint

- ▶ Fully extend the knee prior to heel strike.

NOTICE**Risk of damage to electronic components due to installation errors or improper use**

Incorrect handling of the electronics can cause malfunctions and/or damage to the electronics. Please observe the following safety instructions:

- ▶ Please read the information regarding the operation of the electronics thoroughly and instruct the patient in the use of the electronics (see the information on the functionality of electronic components).
- ▶ Only install electronic components in the thigh area.
- ▶ All electronic connections should be protected against oxidation with silicone grease.
- ▶ Only use the M5 x 10 screws included in the scope of delivery.
- ▶ If electronic components are defective, always replace the entire component with a spare part.

NOTICE

Contact with salt water or water containing chlorine/soap as well as abrasive substances (e. g. sand)

Damage and premature product wear

- ▶ Following any contact with the substances identified above, promptly clean the product in accordance with the section "Cleaning and care".

INFORMATION

When using the system in a knee orthosis, take care to ensure that the orthosis is permanently positioned on the leg.

INFORMATION

Maintenance and repairs to the orthotic knee joint in the area of the bearing are permitted. Repairs to the locking mechanism may only be performed by an Ottobock Service Centre.

5 Preparing the product for use

NOTICE

Damage to the control electronics

Use the dummies included in the scope of delivery for all process steps until the orthosis is completed. Only replace the dummies with the electronic components directly before the fitting or upon completion of fabrication. The upper joint section of the orthotic joint has threaded blind holes to attach the lamination bars. To avoid damaging the control electronics in the upper joint section of the orthotic joint, only use the supplied M5 x 10 screws.

INFORMATION

We recommend fabricating an interim orthosis prior to the definitive orthosis. This makes it possible to prevent alignment errors and incorrect positioning of the E-MAG Active orthotic joint and to check that the orthotic joint is opened and closed reliably.

INFORMATION

Parallel alignment of the orthotic joints

Use the 743R6 alignment fixture to position the orthotic joints on the plaster positive.

Using the lamination dummy

Positioning of the electronic components

The electronic components are positioned laterally on the thigh. This prevents a collision with the contralateral side in bilateral fittings. The optimal position for the electronics is proximal and in the vertical course of the load line. If the electronics and battery are located on one side of the thigh, the cable between the electronics and battery is not subjected to unnecessary strain. **Optional:** The battery can also be positioned on the medial side of the thigh.

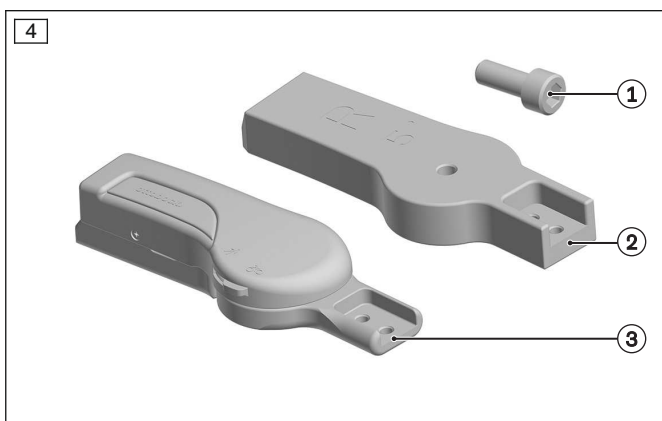

Model the patient-specific plaster positive.

Position the lamination dummy 30Y297* (item 2) of the orthotic joint (item 3) on the compromise pivot point according to Nietert using the slotted oval head screw (item 1) and the 743R6 joint alignment set.

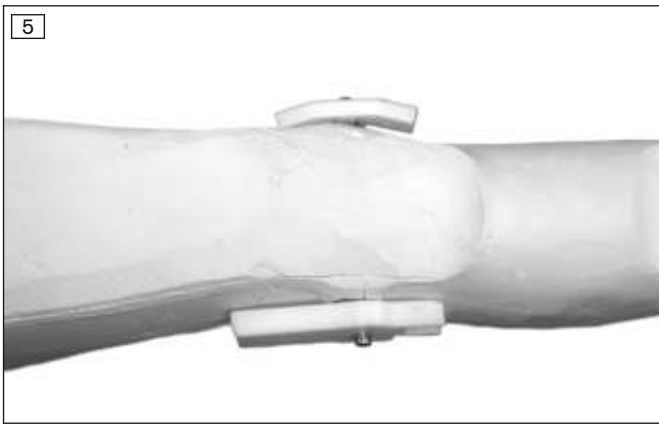

Arrange the 30Y297=* and lamination 317X206=* dummies for the orthotic joints parallel to each other.

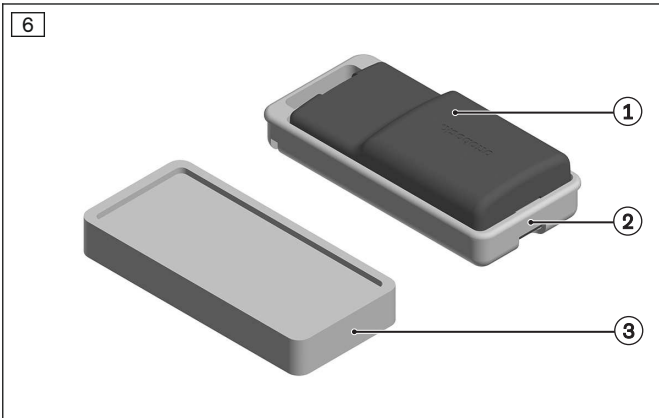

Determine the final positions of the lamination dummies on the region of the thigh.

Components:

1. Battery
2. Receptacle casing
3. Lamination dummy

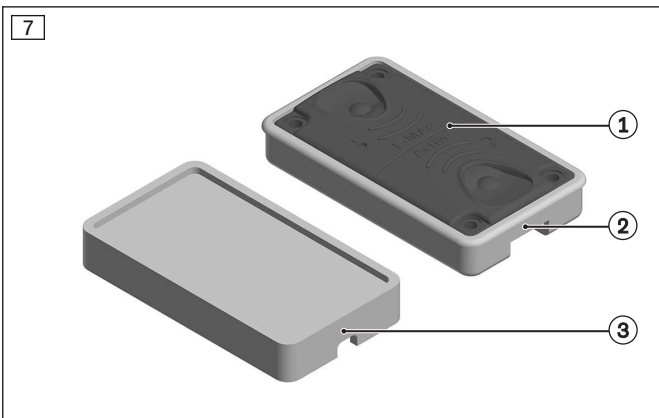

Components:

1. Electronics
2. Battery receptacle
3. Lamination dummy

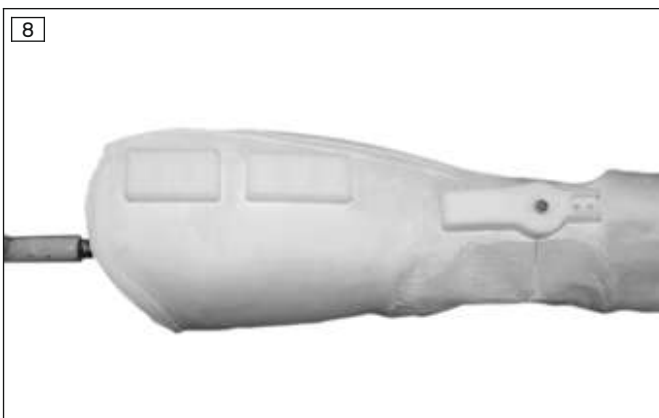

Optionally, the soft tissue regions of the plaster model can be adapted to the shape of the lamination dummies.

Note the length of the cables when positioning the components:

- Battery – electronics: **500 mm**, (variable length)
- Electronics – knee joint: **300 mm**, (fixed length)

Shaping the bars

- 1) Secure the bars in the insertion zone of the lamination dummy using the screws.

- 2) Secure and align the lamination dummy on the model using the slotted oval head screw and the alignment insert.
- 3) Process the bars according to their instructions for use (647G1425).

Mounting the bar

- 1) Clean the threads of the screw connections using a degreasing cleaner.
- 2) Insert the bars into the insertion zone.
- 3) Secure the screws with Loctite 241 and the corresponding tightening torque.

Tightening torque in Nm (lbf in.)	
Screw (see Fig. 1, item 4)	7 (62)
Joint screw (see Fig.1, item 1)	35 (310)

5.1 Working instructions for laminate and thermoplastic technology

Fabrication of the E-MAG Active using the lamination technique

INFORMATION

The manufacturer’s instructions for fabricating an orthosis using lamination technology are included in the 646T591 **technical information**.

- 1) Remove the lamination dummies for the rechargeable battery and the electronics tray.
- 2) Bend the lamination bars and mould the PVC profile material.
- 3) Apply the reinforcement to the bars and laminate the orthosis.

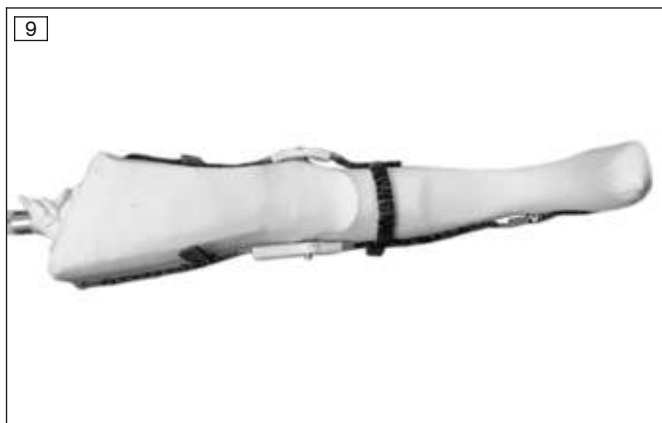

Reinforce the orthosis according to the requirements of the patient profile.

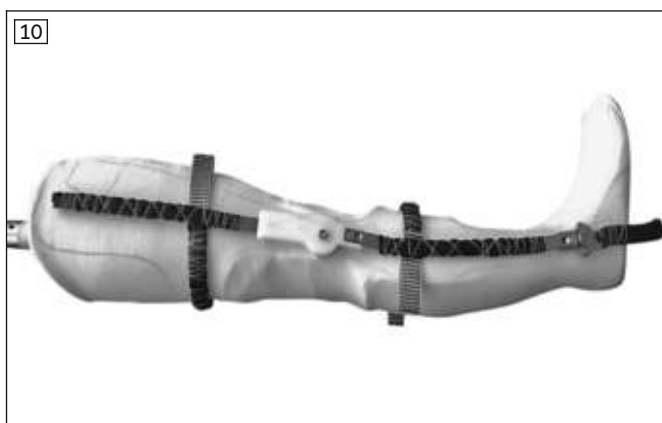

Lateral view.

Fabricating the casing using the lamination technique

CAUTION

Risk of damage due to improper processing

Injuries due to changes in or loss of functionality

- ▶ Make sure that no notches are made in the joint bar material when sawing open the laminate/thermoplastics.

NOTICE

Risk of damage due to improper installation

Incorrect installation can cause malfunctions and/or damage to the orthotic joint. Please observe the following safety instructions:

- ▶ Follow the instructions for use provided for the charger and battery.
- ▶ Use the supplied dummies. Do not process joint or electronic components directly.
- ▶ Follow the installation instructions and the sequence of the individual steps (see Section 3.1).

This section describes how to fabricate a casing for protecting and retaining cables and electronic components.

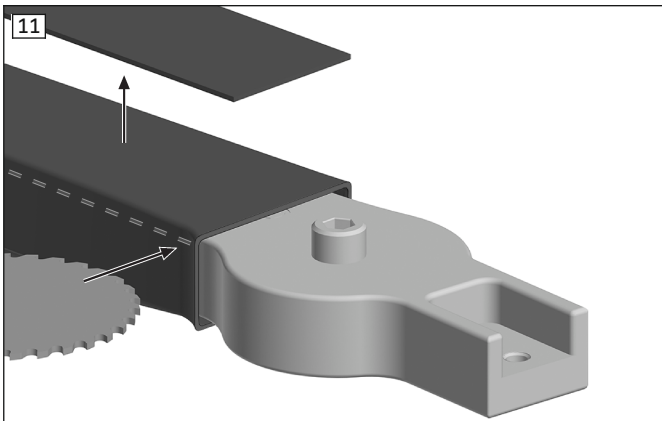

Cut the lamination dummy free.



Mill the cable groove into the lamination dummy.
Position the cable dummy on the model (see fig. 24).

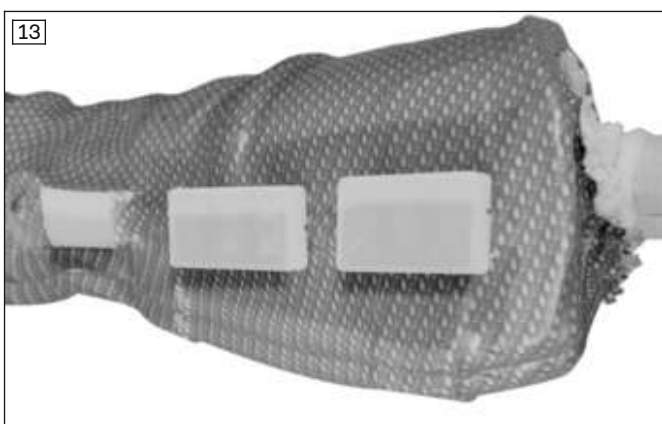

Position the lamination dummies for the electronic components **30 mm** from the edge of the upper part of the orthosis.

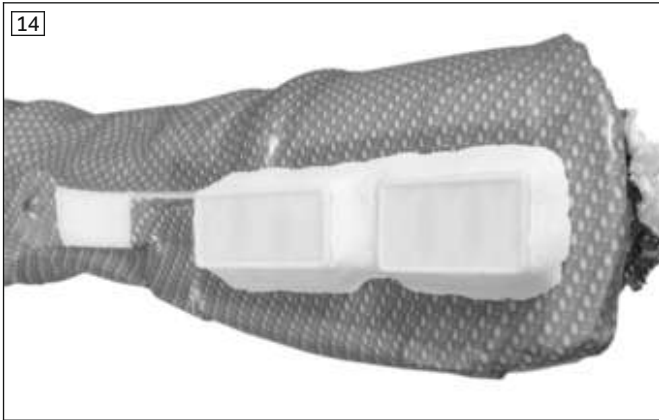

Measure the length of the supplied cable dummies:

- Cable dummy (**7 mm** wide) between the lamination dummies for the knee joint and electronics.
- Perlon wire for the cable connecting the electronics to the battery.



Secure the lamination dummies for the electronic components on the model with double-sided adhesive tape. Fill the edges between the dummies and the socket with plasticine in order to achieve a smooth transition.

Push down the protruding edges with a spatula so there is a distance of **2 mm** between the dummies and plasticine.

Fasten the cable dummies in the designated recesses of the electronics and battery dummies:

- From the orthotic knee joint to the electronics.
- From the electronics to the battery.



Reinforcement of the casing:

- Pull one layer of 99B25 nylon stockinette over the finished orthosis.
- Pull over one PVA bag.
- Pull two layers of Perlon stockinette over the model.
- Secure two layers of woven carbon fibre on the dummies.
- Pull two layers of Perlon stockinette over the model.
- Pull over one PVA bag.
- Laminate the casing.



Demould the casing after it cures.

Carefully sand down the lamination dummies of the battery and its receptacle as well as the electronics and their receptacle to the edges.

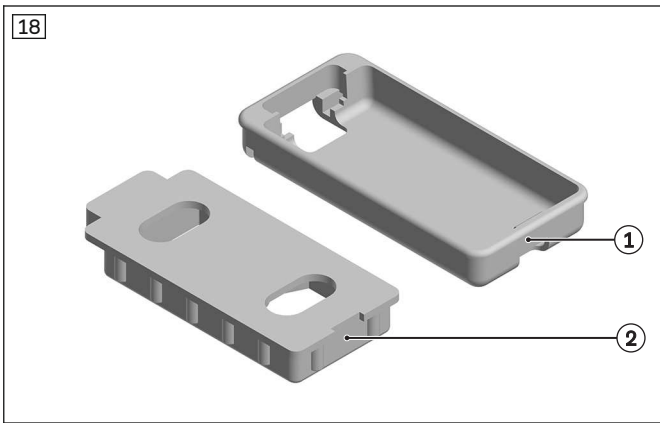

Fully demould the orthosis from the model and remove all dummies and the plasticine.

Sand down the edges of the orthosis and the casing. Insert the dummy (item 2) for the rechargeable battery into the corresponding receptacle (item 1). Position the receptacle in the casing from the outside.

Repeat the steps for the electronics receptacle.



INFORMATION: Ensure that the cable connection of the orthotic joint cable leads to the electronics and the electronics cable to the rechargeable battery.

Secure the receptacles and dummies with PVC adhesive tape from the outside.

Pull the adhesive tape tight to prevent the sealing resin from penetrating during gluing.



NOTICE: Excessive hardener causes the sealing resin to form bubbles and the bonded joint to become brittle.

Rotate the casing so the receptacles are visible from the inside.

Mix the sealing resin.

Glue the receptacle to the casing. To do so, carefully distribute the sealing resin around the receptacles.

Finishing the orthosis

- 1) Clean the threads of the screw connections using a degreasing cleaner.
- 2) Insert the bars into the insertion zone.
- 3) Secure the screws with Loctite 241 and the corresponding tightening torque.
- 4) Prepare the paddings and hook-and-loop closures.

Fabrication of the E-MAG Active using thermoplastic technology

INFORMATION

The manufacturer's instructions for fabricating an orthosis using thermoplastic technology are included in the 646T546 **technical information**.

- 1) Remove the lamination dummies for the rechargeable battery and the electronics tray.
- 2) **Optional:** Position the shaped foot stirrups and joint bars under the thermoplastic material.

21

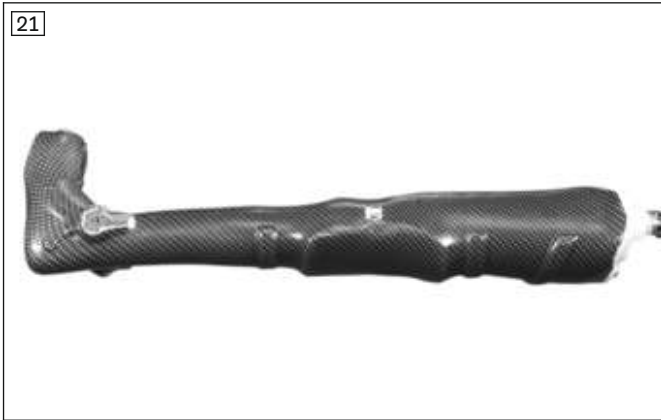

INFORMATION: This example shows the use of 4 mm PP homopolymer 616T20*.

Expose the square channels for the alignment inserts.
Bend the bars.

22



Orthosis with curved bars.

Fabricating the casing using thermoplastic technology

CAUTION

Risk of damage due to improper processing

Injuries due to changes in or loss of functionality

- ▶ Make sure that no notches are created in the joint bar material when milling the laminate/thermoplastics.

NOTICE

Risk of damage due to improper installation

Incorrect installation can cause malfunctions and/or damage to the orthotic joint. Please observe the following safety instructions:

- ▶ Follow the instructions for use provided for the charger and battery.
- ▶ Use the supplied dummies. Do not process joint or electronic components directly.
- ▶ Follow the installation instructions and the sequence of the individual steps (see Section 3.1).

This section describes how to fabricate a thermoplastic casing for protecting and retaining cables and electronic components.



Position the lamination dummies for the electronic components **30 mm** from the edge of the upper part of the orthosis.

Measure the length of the supplied cable dummies:

- Cable dummy (**7 mm** wide) between the lamination dummies for the knee joint and electronics.
- Perlon wire for the cable connecting the electronics to the battery.

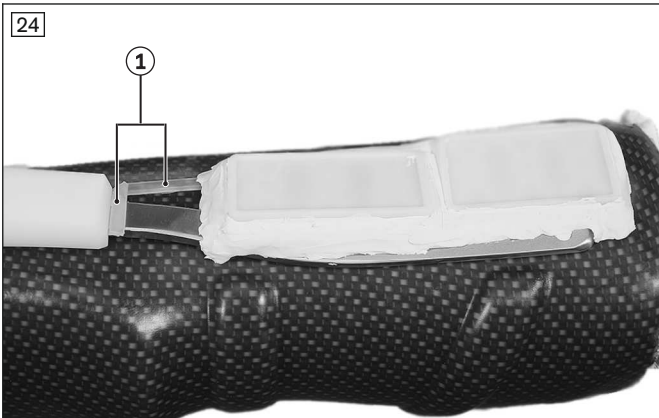

Secure the lamination dummies of the electronic components on the model with double-sided adhesive tape. Fill the edges between the dummies and the upper section of the orthosis with plasticine in order to achieve a smooth transition.

Push down the protruding edges with a spatula so there is a distance of **2 mm** between the dummies and plasticine.

Fasten the cable dummies (item 1) in the designated recesses of the electronics and battery dummies:

- From the orthotic joint to the rechargeable battery.
- From the rechargeable battery to the electronics.

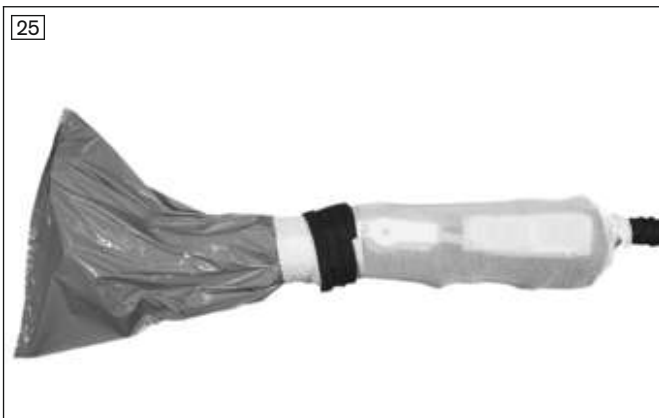

Pull 1 layer of Perlon stockinette over the model. Isolate the distal end with a plastic bag and fixate with sealing **627B5*** tape.



Heat the **2 mm** PP homopolymer to the processing temperature. Pull the thermoplastics over the model and apply vacuum.



Demould the casing after it cools.
Carefully sand down the lamination dummies of the battery and its receptacle as well as the electronics and their receptacle to the edges.

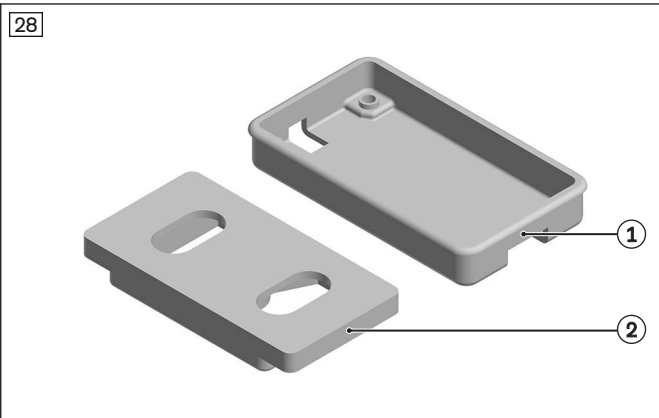

Fully demould the orthosis from the model and remove all dummies and the plasticine.
Sand down the edges of the orthosis and the casing.
Insert the dummy (item 1) for the electronics into the corresponding receptacle (item 2). Position the receptacle in the casing from the outside.
Repeat the steps for the battery receptacle.



Secure the receptacles and dummies with PVC adhesive tape from the outside.
Pull the adhesive tape tight to prevent the 617H46 bonding agent from penetrating during gluing.
Rotate the casing so the receptacles are visible from the inside.
Glue the receptacle to the casing. To do so, carefully distribute the bonding agent around the receptacles.
Allow the adhesive to cure for **12 hours**.



Mount the cables for the orthotic joint and the electronic components (see page 19).

Finishing the orthosis

- 1) Clean the threads of the screw connections using a degreasing cleaner.
- 2) Insert the bars into the insertion zone.

- 3) Secure the screws with Loctite 241 and the corresponding tightening torque.
- 4) Prepare the paddings and hook-and-loop closures.

5.2 Installing the electrical components

NOTICE

Risk of cable damage

Shortening, extending and frequent bending can destroy the cables between the joint and electronics, and between the battery and electronics. If possible, do not bend or crease the electronics cables until they are ready to be fastened into their final positions.

NOTICE

Risk of short circuit

Do not insert the battery until the entire system has been assembled.

NOTICE

Risk of damage to electronic components

Dust, moisture and heat may destroy the electronics.

- ▶ Always seal the electronics on the E-MAG orthotic joint before sanding or performing other work on the orthosis.
- ▶ Loosen bonded components mechanically. Do not use a hot air gun.

INFORMATION

The E-MAG orthotic joint is equipped with polarity protection: If the polarity is incorrect, the electronics are turned off to prevent a short circuit. If the E-MAG orthotic joint does not indicate operational readiness for no apparent reason after the cables are connected, please check the polarity.

INFORMATION

Please ensure that the full cable cross-section is maintained after shortening.

INFORMATION

The casing and the electronics cable should be removed when working on the orthosis. In order to do so, disconnect the cable directly on the E-MAG orthotic joint.



NOTICE:

The cable between the orthotic joint and electronics may not be shortened or extended.

INFORMATION: If there is excess cable length, lay the cable in flat loops and secure it in the casing with double-sided adhesive tape.

To install the electrical components, remove the dummies for the electronics and battery from the receptacles.

Connect the electronics cables to the electronics shell.

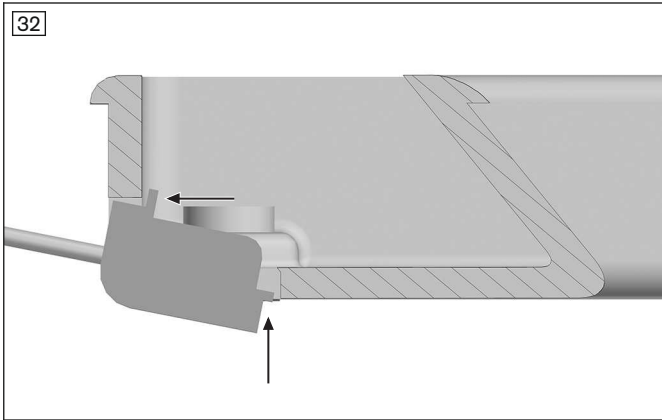

Connect the cable clips to the electronics shell.
INFORMATION: Ensure that the cable clips engage firmly.

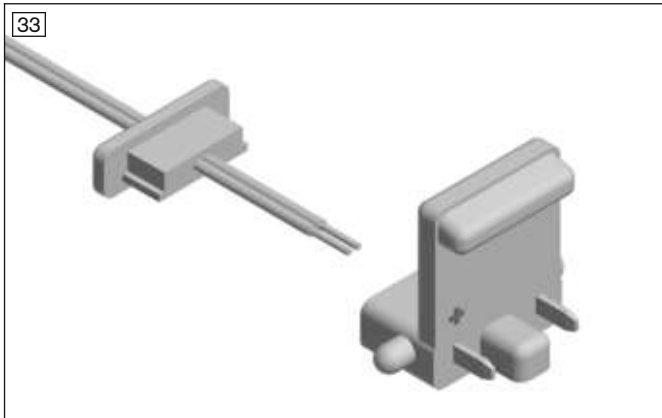

INFORMATION: Leave 5 cm additional cable length to allow for installation of the locking unit. Ensure the correct polarity is maintained after shortening: plus cable (red) to plus connection (+ symbol on locking unit), minus cable (grey) to minus (no symbol).

Optionally, you may shorten the battery cable in the battery plug section. Ensure that the cable cross-section is maintained.

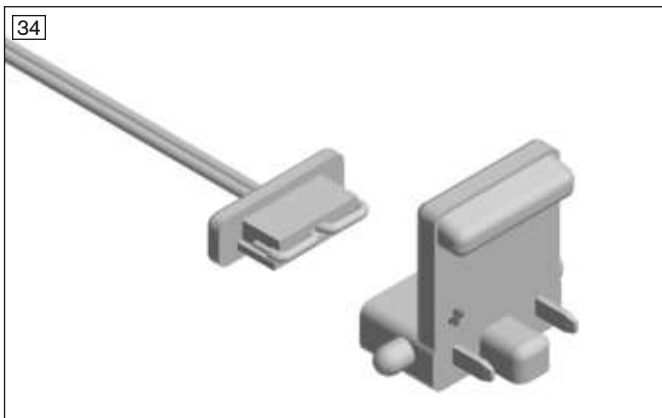

Connect the battery plug to the locking unit.



Thread the battery cable through the receptacle.

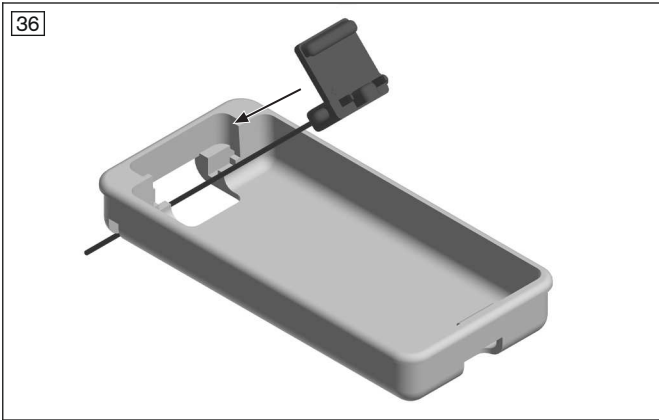

Place the plug in the battery tray.

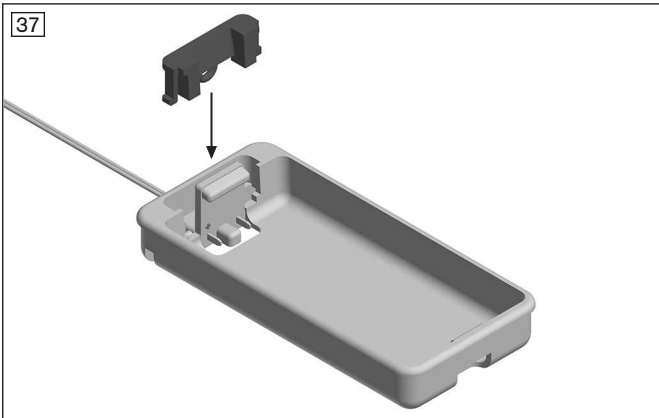

Insert the locking unit into the battery tray.



Install the cable from the electronics to the rechargeable battery and secure it in the cable channel of the casing with double-sided adhesive tape.



INFORMATION: Apply 633F11 silicone grease to protect the contacts and cable connections against oxidation.

Apply silicone grease to the contacts of the electronics.



Insert the electronics into the receptacle.



Fasten the electronics using the supplied screws at a maximum torque of **1 Nm**.

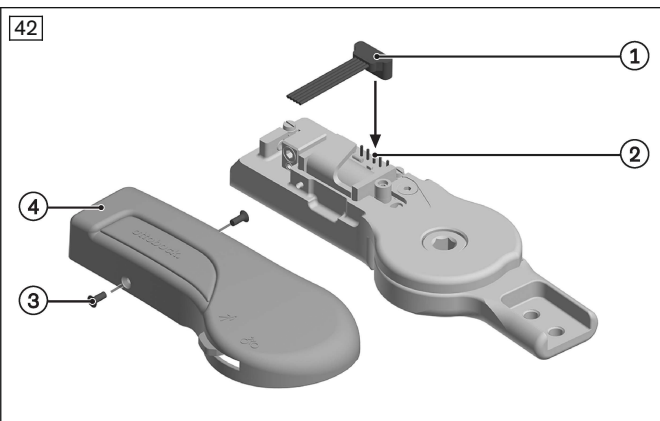

Connect the electronics cable to the orthotic joint:
Loosen the countersunk screws (item 3) and remove the cover (item 4).
Apply silicone grease to the contacts of the plug contacts (see fig. 39).
Connect the electronics cable (item 1) to the plug contacts (item 2).

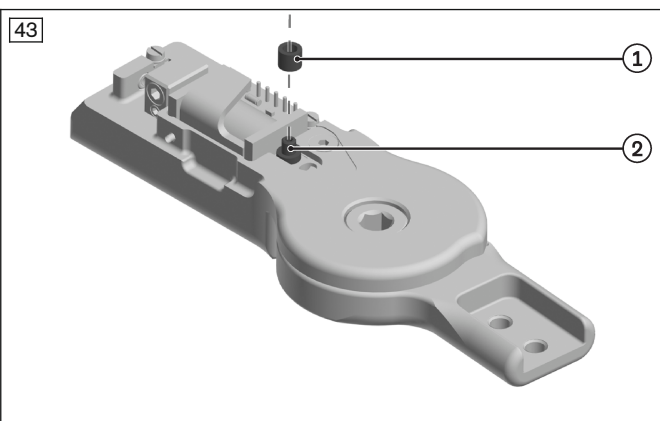

INFORMATION: When removing the joint cover, ensure that the roller (item 1) stays positioned on the disconnect pin (item 2) to enable secure temporary unlocking.

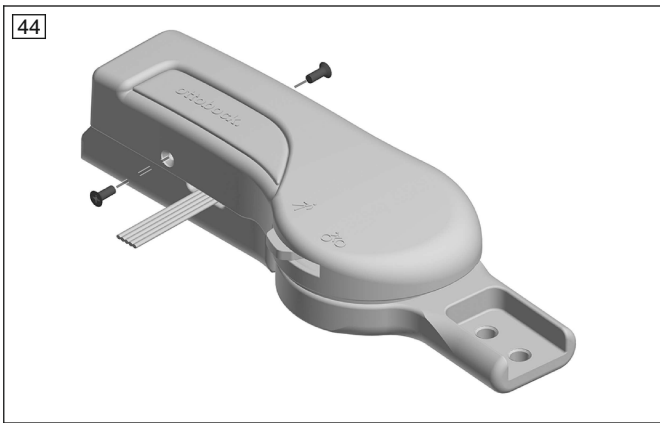

Screw the cover onto the orthotic joint.

Secure the casing on the upper part of the orthosis. Once the rechargeable battery is inserted and fully charged, the orthotic joint is ready for operation.

5.3 Working instructions for electronic components

5.3.1 Control electronics

The electronic control unit measures the position of the orthosis during the gait cycle and unlocks the orthotic joint prior to toe-off. Prior to heel strike at the end of the swing phase, the orthotic joint is locked in the extended position so the user can step down safely. In order to determine the optimal activation point of the orthotic joint for the patient, the electronics are equipped with an automatic calibration feature. This must be activated by the O&P professional during the initial patient fitting. A further helpful feature is the test mode, which provides acoustic feedback on joint activity during walking so the O&P professional can determine the settings.

Two switching options are available to the patient. The sitting or locking function can be activated or deactivated with the two press buttons.

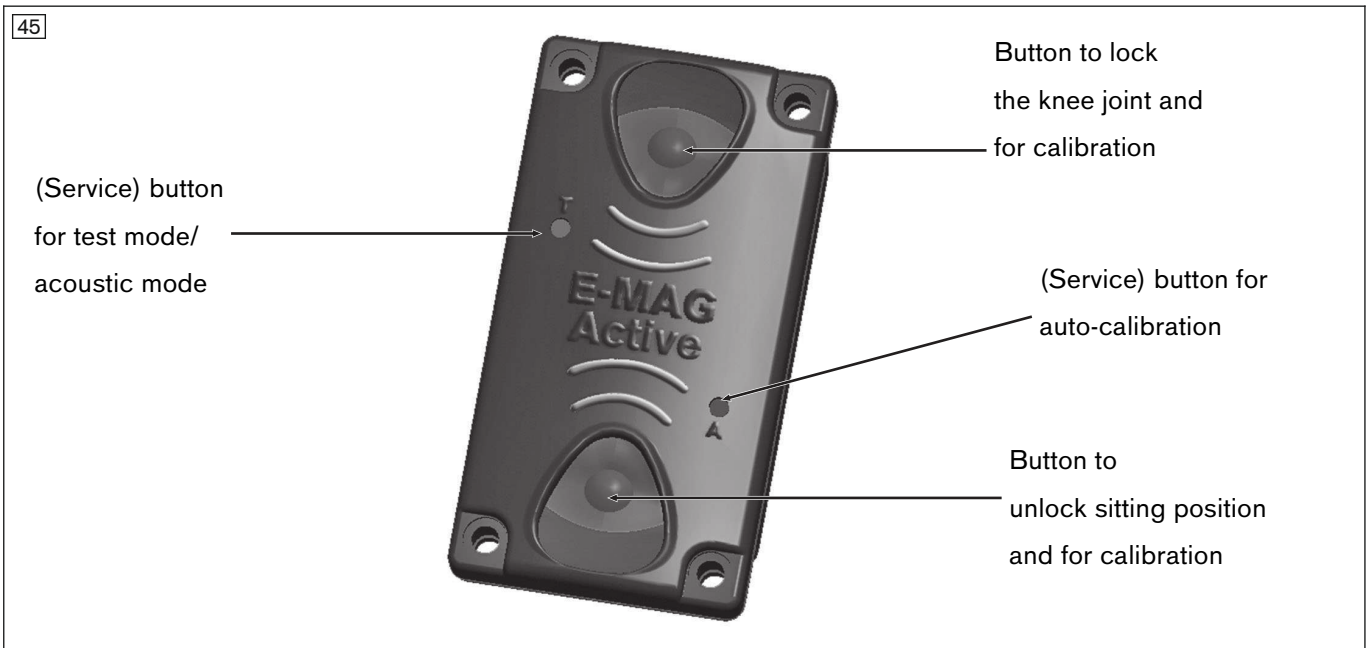

5.3.1.1 Power-on self test – initial battery installation

After all cables are connected, the battery can be inserted. The contacts have to face up and in. In order to do this, insert the battery into the receptacle at an angle and press it against the orthosis. You can hear the battery lock into place when it is properly inserted.

This initiates a self-test of the system that is performed each time the battery is inserted again. Three different audible signals may be emitted:

- 1) A brief illumination of the LEDs and a short rising tone:
When the battery is inserted, the orthotic joint is closed and the system signals OK.
- 2) The green and white LEDs flash and a continuous alternating tone sequence (tone, pause, tone) is emitted.
The system signals OK when the orthotic joint is moved into extension.

- 3) Sensor error. Continuous illumination (red) and continuous tone.
Remove and then reinsert the battery.

5.3.1.2 Initial walking in test mode

Perform initial walking attempts (Figure see fig. 46) between parallel bars or at least with the help of crutches. In order to make the orthotic joint easy to unlock, a test mode can be activated which does not look for an optimised setting but instead opens the orthotic joint in a defined toe-off position (provided the patient's knee joint is extended).

- 1) Press the T button for at least **5 seconds** until the system reports that it is ready.
- 2) The patient takes a step forward to simulate heel strike. The technician pushes the top button B. Confirmation is indicated by a white light and low-high tone.
- 3) The patient takes a step back to simulate the end of the stance phase, i.e. shortly before toe-off. The technician confirms by pressing the bottom press button C. Once again, confirmation is indicated by a white light and low-high tone. Switching processes of the electronics are also confirmed by an audible signal in addition to controlling the orthotic joint. **INFORMATION: These settings are not saved and are intended for test purposes only!**
- 4) Test mode is deactivated by removing the battery.

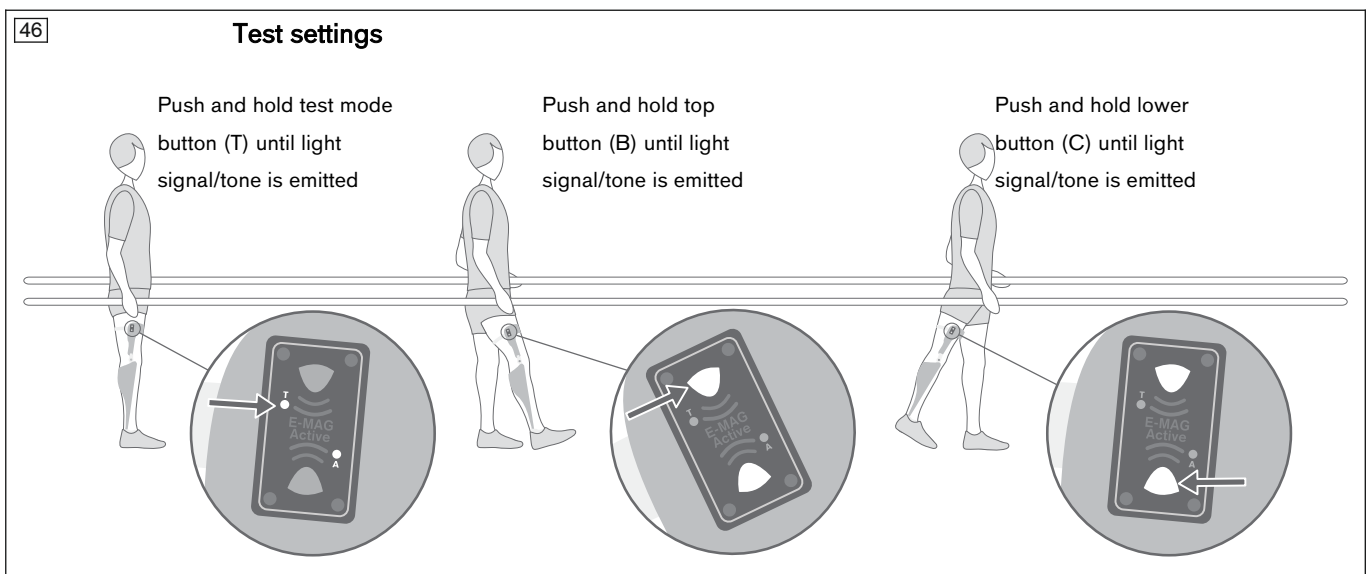

5.3.1.3 Auto-calibration

INFORMATION
Auto-calibration requires the battery to be removed and reinserted after the test mode.

The purpose of auto-calibration is to adjust the electronics to the respective gait pattern of the patient. The settings are independent from the position of the electronics on the orthosis, the design of the orthosis and the fitting side of the patient. We recommend installing the electronics in the vicinity of the hip and the load line (i.e. vertical to the load) in all cases. This allows the patient to easily switch the orthosis functions from the inside of the trouser pocket.

5.3.1.4 Auto-calibration adjustment

The electronics need to be calibrated prior to initial use on the patient. Once the settings have been successfully established for the patient, the calibration process does not have to be repeated. However, the calibration can be reset at any time if the patient's gait pattern changes (see fig. 47).

Calibration process:

- 1) During initial use, the patient should stand between parallel bars to ensure their safety at all times.
- 2) The O&P professional removes the battery and reinserts it. The technician then activates calibration mode by pushing and holding the auto-calibrate button (see fig. 47) until an audible tone and light signal are emitted.
- 3) The patient is asked to start taking a step forwards with the leg that is fitted with the orthosis (position similar to heel strike). The patient briefly remains in this position until the technician confirms the position by pressing the top button B (see fig. 47). A brief audible tone combined with a white light indicates confirmation.
- 4) The patient is then asked to simulate toe-off by positioning the leg behind the body's centre of gravity. The position is confirmed again by pressing the lower press button C. An audible and light signal follow.

- 5) The software now reports that the orthotic joint is in calibration mode. The patient can then walk in the locked state until the software uses a different audible tone to warn the patient that the orthotic joint is about to automatically unlock at the end of the stance phase in order to facilitate an unobstructed swing-through. The system tries to find the optimal switching point.
- 6) The calibration process is complete when the system indicates the orthotic joint is ready by means of an audible tone (long, low tone, followed by long, high tone) and a light signal (continuous green-white light). These settings are then saved by the software. If the technician or patient is not satisfied with the settings, steps 1 – 5 can be repeated as often as desired.

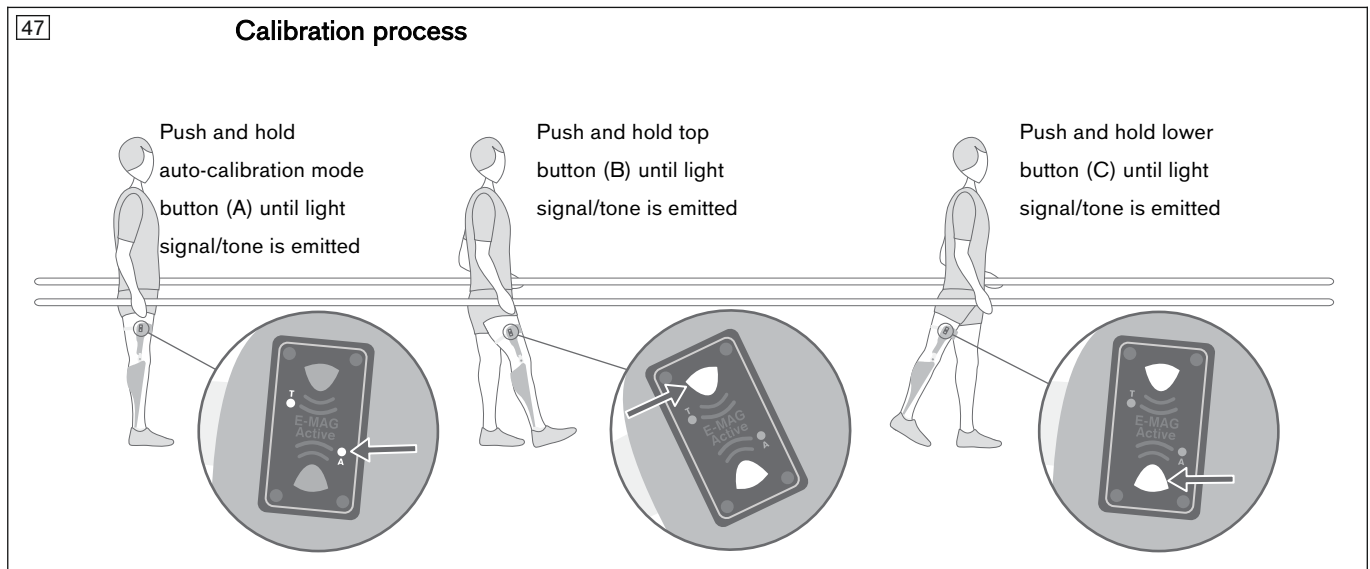

5.3.1.5 Function and activation of acoustic mode after successful calibration

Acoustic mode is used to check whether the switching points were adjusted precisely during calibration. Due to an incorrect patient movement or if the orthosis alignment is not yet optimised, the switching points may deviate. In acoustic mode, an audible signal is emitted in parallel to controlling the orthotic joint during switching processes of the electronics. The acoustic signal confirms the opening and closing of the orthotic joint.

Acoustic mode is activated by pressing the button **T**.

5.3.1.6 Electronic unlocking (once)

With the lower press button **C**, the patient can unlock the orthotic joint once (e.g. in order to sit down). They can do this by briefly pressing button **C** twice in quick succession (like double-clicking a computer mouse). This function is not confirmed by an audible signal.

5.3.1.7 Electronic locking (permanent)

If the patient feels unsafe, they can lock the orthotic joint using the top press button **B**. This might be the case when walking on a slope or if the patient wants to stand for an extended period of time without focusing on the electronic control device. They can do this by briefly pressing button **B** twice in quick succession (like double-clicking a computer mouse). This function is confirmed by an audible signal.

The locking function is deactivated by pressing the upper button **B** twice in quick succession until an audible signal is heard.

5.3.1.8 Mechanical unlocking (temporary)

CAUTION

Risk of injury due to unlocking of the orthotic joint

After activating the release mechanism / unlocking feature (switch to "🚲"), the orthotic joint is not secured by the E-MAG Active system. In order to use the orthotic joint for walking (switch to "🚶"), it must be secured again through the release mechanism.

For certain activities (such as cycling), it may be useful to temporarily unlock the orthotic joint. Mechanical unlocking of the orthotic joint is effected directly on the orthotic joint (switch to "🚲").



The unlocking feature needs to be cancelled in order to restore the functionality of the orthotic joint. In order to secure the orthotic joint again, the switch is operated in the opposite direction. The normal state of the orthotic joint is indicated by the symbol of a walking person (switch to "🚶").

CAUTION

Risk of falling due to unlocking/locking

Both permanent and one-time unlocking as well as permanent locking of the orthotic joint can result in an elevated risk of falling. The patient should not use these functions whilst walking.

5.3.1.9 Alarm configuration

Signal	Visual feedback (LEDs)	Acoustic feedback	Tone/length
Battery low	alternate flashing (white and red)		High-low series/individual signals
Battery empty			Falling/long

The “Low battery” warning indicates that the battery charge level is low. If the battery is not replaced, the warning is repeated after each status signal. The electronics will turn off if the battery power is insufficient. In this case, the orthotic joint can also be opened manually.

5.3.1.10 Rechargeable battery

INFORMATION

Please read the instructions for use of the battery and charger carefully before using the battery for the first time. In particular, please be sure to take note of the safety information provided.

INFORMATION

The battery should always be removed when the orthosis is not in use.

INFORMATION

Failure to unlock the orthotic joint for more than one hour automatically causes the electronics to switch to standby mode. The electronics are reactivated by simply pressing the top press button.

The 17B203=* orthotic joint may only be operated with the 317B20 rechargeable battery provided (see fig. 1, item 6). Prior to initial use, the battery should be charged using the 317L20 battery charger. Insert the battery into the receptacle and make sure it engages. The electrical contact will be made when the mechanical locking mechanism is engaged.

5.3.1.11 Battery charger

INFORMATION

Read the instructions for use for the charger thoroughly before using the charger. In particular, be sure to take note of the safety information provided.

INFORMATION

The LEDs on the charger must not be illuminated prior to inserting the battery. If they are illuminated, please submit the charger to an authorised Ottobock Service Centre.

The 317L20 Ottobock battery charger is intended exclusively for charging the 317B20 batteries.

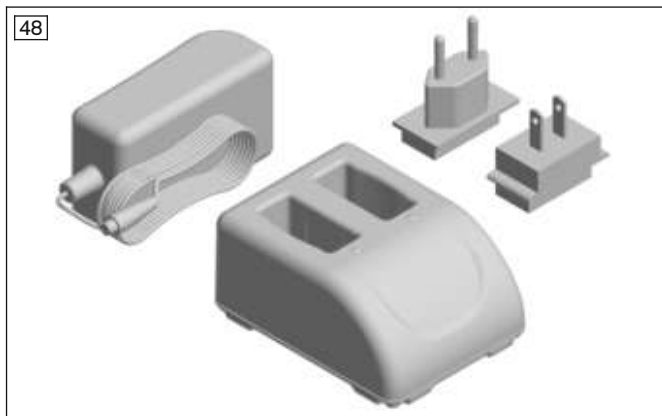

6 Cleaning

After contact with water containing salt, chlorine or soap, or if they get dirty, the orthotic joints must be promptly cleaned.

- 1) Clean the joint with a damp cloth when needed.
- 2) Dry it with a lint-free cloth and allow it to air dry fully. Do not expose to direct heat sources (e.g. sunlight, stove or radiator).

7 Maintenance

⚠ CAUTION

Unallowable use of lubricants

Risk of injury and loss of functionality as well as damage to the product

- ▶ The product is designed to be free of lubricants. Avoid contact with lubricants (e.g. grease, oil).
- ▶ After contact with lubricants, promptly clean the product or parts of the product with a degreasing cleaning agent (e.g. acetone or isopropyl alcohol).

NOTICE

Do not make any structural changes to mechanical or electronic system components.

INFORMATION

There is a serial number on the E-MAG case. Take note of it. It serves as proof of the guarantee and is used to identify the corresponding electronic components.

7.1 Verification of functionality and inspection for wear

⚠ CAUTION

Risk of malfunction due to disassembly

The magnet (see fig. 50, item 8), electronics (see fig. 50, item 2) or disconnect pin (see fig. 50, item 7) must not be loosened or removed, since this can influence the functionality of the orthotic joint.

INFORMATION

Document your maintenance work and intervals. The maintenance schedule at the end of this document serves as a template for making copies. We recommend including a copy in your documentation after each maintenance order is completed. Also be sure to inform your customer about the required maintenance intervals.

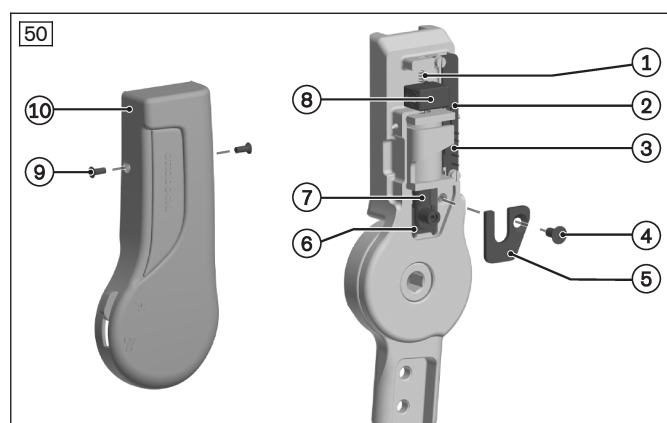

INFORMATION: If the magnet, electronics or disconnect pin malfunction, contact Ottobock Support.

Check the components of the orthotic joint for soiling: Loosen the countersunk screws (item 9) and remove the cover (item 10).

Optional: Remove dirt from the spring (item 1) and lock (item 6) using a brush.

Optional: Clean the plug contacts (item 3) with a brush and then grease them with silicone.

To check the lock, remove the countersunk screw (item 4) and the lock cover (item 5).

Replacing joint components (see fig. 2)

Replace the components if there is wear and tear to the axial washer (item 2), bearing bushing (item 7) or ELADUR bumper (item 5):

- 1) Remove the joint screw (item 1).
- 2) Disassemble the upper joint section (item 8) from the lower joint section (item 3).

- 3) **Optional:** Replace the axial washer (item 2).
INFORMATION: Only use a washer of the same colour when replacing the axial washer contained in the 17BS203 maintenance set.
- 4) **Optional:** Replace the bearing bushing (item 7) (included in the 17BS203 maintenance set).
- 5) **Optional:** replace the Eladur bumper (item 5) (included in the 17BS203 maintenance kit).
- 6) Assemble the orthotic joint and secure the joint screw with a tightening torque of **35 Nm**.

7.2 Maintenance schedule

Maintenance schedule for regular service		E-MAG Active		Patient:
First used on:	Serial number:	Left <input type="checkbox"/>	Right <input type="checkbox"/>	Patient weight [kg]:
				User height [cm]:
Medial support serial number:		Inspection (checklist for ticking off)		
Item	Department	Yes	No	Measure
1	Orthotic knee joint			
	Dirt/wear and tear?			
	Play in the joint when locked (ML)?			
	Play in the joint when unlocked (ML)?			
	Problem-free unlocking/locking function?			
	Noise?			
	Knee electronics cable connection?			
	Tight connection between bars/joints?			
2	Medial support			
	Play in the joint when unlocked?			
	Noise?			
	Tight connection between bars/joints?			
3	Electronics			
	Cable connections tight and undamaged?			
	Plug connections clean and free of oxidation?			
	Control electronics – correct settings?			
	Blue buttons ok?			
	Tone and light signals ok?			
	Correct activation of stance and swing phase?			
4	Battery and battery charger			
	Battery ok, no damage?			
	Battery connections clean and free of oxidation?			
	Battery lock operates easily and contacts are clean?			
	Function of battery charger ok?			
Notes				
	Do the settings meet the patient's requirements?			
	The maintenance was carried out	by:	
		on:	

8 Faults and troubleshooting

NOTICE

Risk of short circuit

Never open electronic components. If there is a defect, send all electronic components to Ottobock. **Optional:** Replace the 317E2 electronics cable and the 317E20 battery connection cable.

INFORMATION

The orthotic joint remains locked when the electronic components fail.

► Remove and then reinsert the battery in order to restart the electronics.

Defects of electronic components are indicated by a continuous light or tone.

The **17B203=L-S**, **17B203=R-S** service set is available for repairs.

The service set is subject to a rental fee outside the warranty period. When sending the E-MAG Active for service, please be sure to include all of the following components: orthotic joint, electronics, battery, battery charger, case with serial number.

8.1 System does not start

If the system does not start, remove the battery and reinsert it. Should the system still fail to start, there is a defect in the electronics. Check the cable system and contacts. Reinsert the battery. If the system still does not start, replace the electronics.

8.2 Lock does not close

If the lock of the E-MAG Active does not engage, check the following in sequence:

- 1) alignment of the orthosis, and if the orthosis wearer reaches the required extension,
- 2) the axial washer and bushing with collar for wear or dust particles inside the orthotic joint. If both checks do not respond, replace the orthotic joint.

9 Repair

Replacing the battery cable

To replace the battery cable, complete the assembly steps (see page 19) in reverse order.

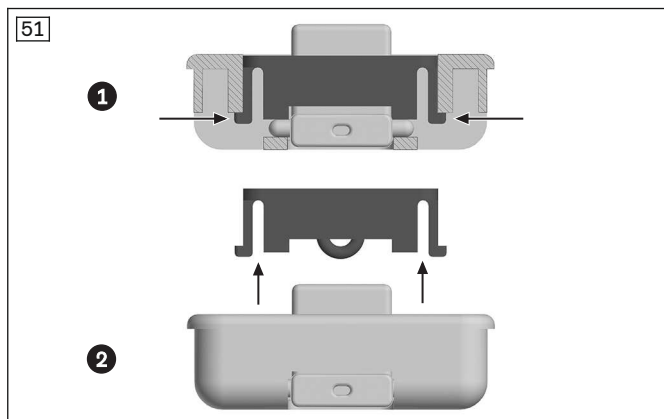

1. Press in the lugs of the ratchet unit.
2. Take the ratchet unit out of the battery tray.

10 Technical data

Storage temperature range	-20 °C to +70 °C (-4 °F to 176 °F)
Operating temperature range	-15 °C to +50 °C (-5 °F to 122 °F)
Relative humidity for both ranges	15% to 93%
Power supply for joint	NiMh battery, 4.8 V nominal voltage
Range of a battery pack	Approx. 5,000 steps, corresponds to about 5 km

11 Disposal

Dispose of the product in accordance with national regulations.

12 Legal information

All legal conditions are subject to the respective national laws of the country of use and may vary accordingly.

12.1 Liability

The manufacturer will only assume liability if the product is used in accordance with the descriptions and instructions provided in this document. The manufacturer will not assume liability for damage caused by disregarding the information in this document, particularly due to improper use or unauthorised modification of the product.

12.2 CE conformity

The product meets the requirements of Regulation (EU) 2017/745 on medical devices. The CE declaration of conformity can be downloaded from the manufacturer's website.

The product meets the requirements of the RoHS Directive 2011/65/EU on the restriction of the use of certain hazardous substances in electrical and electronic devices.



Ottobock SE & Co. KGaA
Max-Näder-Straße 15 · 37115 Duderstadt · Germany
T +49 5527 848-0 · F +49 5527 848-3360
healthcare@ottobock.de · www.ottobock.com