



# Avantgarde 4

EN Instructions for use (user) ..... 3



# Table of contents

EN

<b>1</b>	<b>Foreword</b> .....	<b>5</b>
<b>2</b>	<b>Product description</b> .....	<b>6</b>
2.1	Function .....	6
2.2	Product overview .....	6
<b>3</b>	<b>Intended use</b> .....	<b>9</b>
3.1	Indications for use .....	9
3.1.1	Special features of the CLT and CLT Ultra options .....	9
3.2	Indications .....	9
3.3	Contraindications .....	9
3.3.1	Absolute Contraindications .....	9
3.3.2	Relative Contraindications .....	9
<b>4</b>	<b>Safety</b> .....	<b>9</b>
4.1	Explanation of warning symbols .....	9
4.2	Safety instructions for use .....	9
4.3	Side effects .....	13
4.4	Further information .....	13
4.5	Nameplate and warning labels .....	13
<b>5</b>	<b>Delivery</b> .....	<b>14</b>
5.1	Scope of delivery .....	14
5.2	Options .....	14
5.3	Storage .....	14
5.3.1	Storage during daily use .....	14
5.3.2	Storage during extended disuse .....	14
<b>6</b>	<b>Preparing the product for use</b> .....	<b>14</b>
6.1	Assembly .....	14
<b>7</b>	<b>Use</b> .....	<b>15</b>
7.1	Instructions for use .....	15
7.2	Getting in and transferring .....	16
7.3	Legrests .....	16
7.3.1	Removing and attaching the leg supports .....	16
7.3.2	Folding the foot plate up and down .....	17
7.3.3	Adjusting the angle of the elevating leg support .....	18
7.3.4	Removing and fastening the calf strap .....	19
7.3.5	Adjusting the leg supports .....	20
7.4	Seat cushion and back upholstery .....	20
7.4.1	Removing and fastening the seat cushion .....	20
7.4.2	Removing and fastening the back support pad .....	20
7.5	Backrest .....	21
7.6	Side panels .....	21
7.6.1	Removing the side panels .....	21
7.6.2	Adjusting the height of the forearm support .....	22
7.6.3	Removing the separate "swing away arm support" with padding .....	22
7.6.4	Adjusting an arm support with swivel unit .....	22
7.7	Push handles .....	23
7.7.1	Adjusting the height of the push handles .....	23
7.7.2	Removing the push handles .....	23
7.8	Stabiliser bar .....	24
7.9	Drive wheels .....	24
7.9.1	Removing and mounting the drive wheels .....	25
7.9.2	Rear wheel with one-handed operation (double push rings) .....	26
7.10	Caster wheels and caster forks .....	27
7.10.1	Approach in case of stiffness .....	27
7.11	Wheel locks .....	27
7.11.1	Using the wheel locks .....	28

7.11.2	Drum brake .....	29
7.11.3	Knee lever wheel lock for user and attendant .....	29
7.11.4	Using the plug-on wheel lock lever extension .....	30
7.12	Anti-tipper/tip-assist .....	31
7.12.1	Activating and deactivating the anti-tipper .....	31
7.12.2	Using the tip-assist .....	32
7.13	Transport wheels .....	32
7.13.1	Using the transport wheels .....	32
7.14	Lap belt (seat belt) .....	33
7.15	Tray .....	33
7.16	Additional options .....	35
7.17	Disassembly and transport .....	35
7.18	Use in vehicles for transporting persons with reduced mobility .....	36
7.18.1	Avantgarde DV/DS without CLT and CLT Ultra options .....	36
7.18.1.1	Required accessories .....	36
7.18.1.2	Using the product in a vehicle .....	37
7.18.1.3	Restrictions for use .....	39
7.18.2	CLT and CLT Ultra options .....	40
7.19	Care .....	40
7.19.1	Cleaning .....	40
7.19.1.1	Cleaning by hand .....	40
7.19.1.2	Cleaning the seat cushion .....	41
7.19.1.3	Cleaning belts/straps .....	41
7.19.2	Disinfection .....	41
<b>8</b>	<b>Maintenance and repair .....</b>	<b>42</b>
8.1	Maintenance .....	42
8.1.1	Maintenance intervals .....	42
8.1.2	Maintenance tasks .....	42
8.2	Repair .....	43
8.2.1	Inner tube, rim tape and tyre replacement .....	43
<b>9</b>	<b>Disposal .....</b>	<b>44</b>
9.1	Disposal information .....	44
<b>10</b>	<b>Legal information .....</b>	<b>44</b>
10.1	Liability .....	44
10.2	Warranty .....	44
10.3	Service life .....	44
<b>11</b>	<b>Technical data .....</b>	<b>45</b>
<b>12</b>	<b>Appendices .....</b>	<b>46</b>
12.1	Threshold values for wheelchairs transportable by train .....	46

# 1 Foreword

## INFORMATION

Date of last update: 2020-03-16

- ▶ Please read this document carefully before using the product and observe the safety notices.
- ▶ Obtain instruction from the qualified personnel in the safe use of the product.
- ▶ Please contact the qualified personnel if you have questions about the product or in case of problems.
- ▶ Report each serious incident in connection with the product, in particular a worsening of the state of health, to the manufacturer and to the relevant authority in your country.
- ▶ Please keep this document for your records.

## INFORMATION

- ▶ New information regarding product safety and product recalls as well as the declaration of conformity can be obtained at [oa@ottobock.com](mailto:oa@ottobock.com) or from the manufacturer's service department (see inside or outside of back cover for addresses).
- ▶ You can request this document as a PDF file at [oa@ottobock.com](mailto:oa@ottobock.com) or from the manufacturer's service department (see inside or outside of back cover for addresses). The PDF file can also be displayed in a larger size.

You have received a product that is very versatile for everyday use at home and outdoors.

In order to exclude injuries of any type, familiarise yourself with the handling, functions and intended use of the product before using it. These instructions for use provide you with the related necessary information.

### **Please note the following in particular:**

- All users and/or their attendants must be trained by qualified personnel in the use of the product. In particular, users and/or attendants must be informed of the residual risks with the aid of the safety notices in the instructions for use (user).
- The product was adapted to the needs of the user. Subsequent changes may be made only by qualified personnel. We recommend checking the product settings **once per year** to ensure optimal treatment over the long term. Especially for users with a changing anatomy (for example body dimensions, weight), an adjustment at least **once every six months** is recommended.
- Your product may differ from the models shown. In particular, not all the options described in these instructions for use will be installed on your product.
- The manufacturer reserves the right to make technical changes to the model described in these instructions for use.

## 2 Product description

### 2.1 Function

The wheelchair is intended exclusively for transporting one person on the seat.  
The wheelchair can be used on solid ground both indoors and outdoors.

### 2.2 Product overview

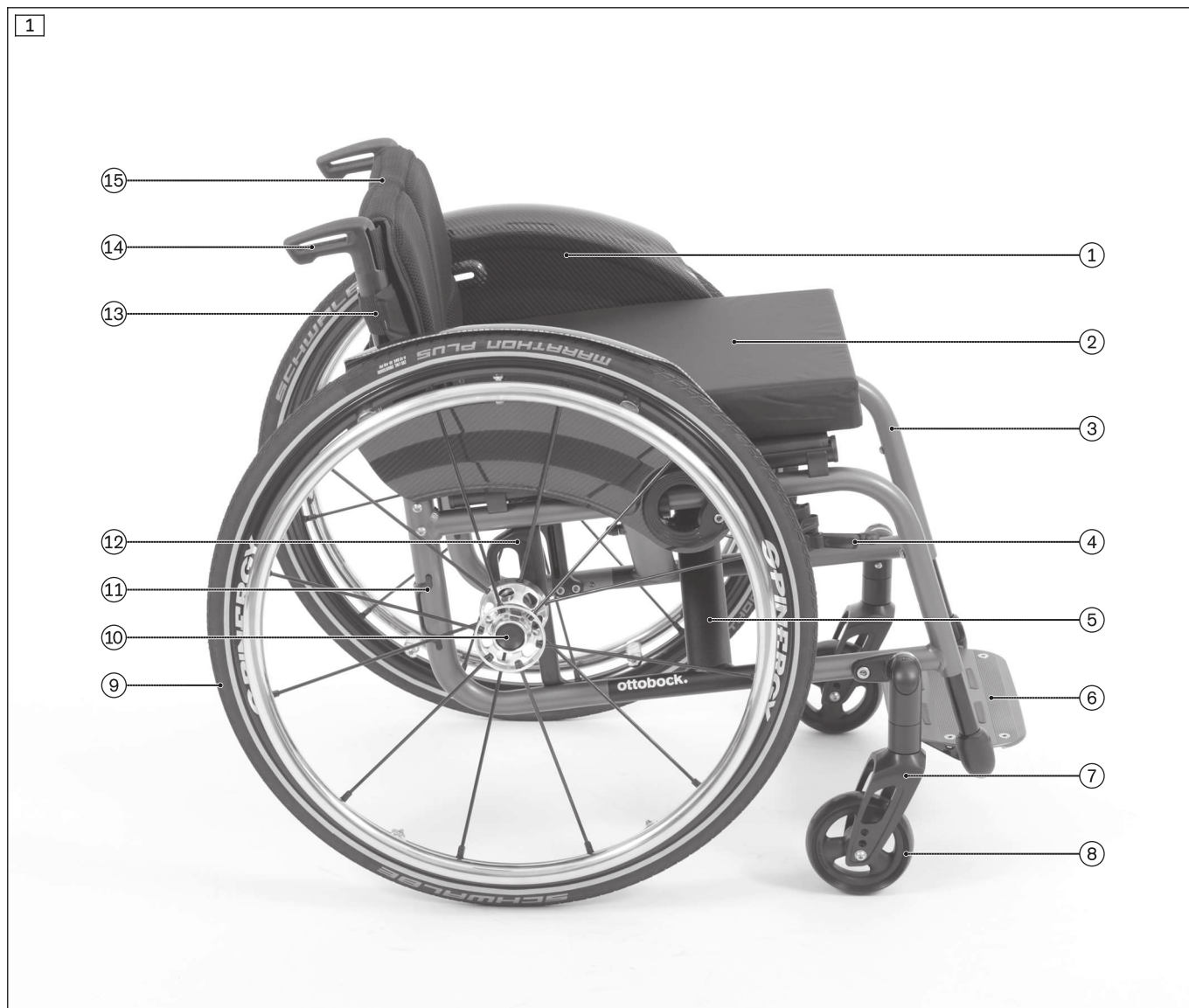

#### Avantgarde DS

**Maximum load** (in combination with double crossbrace): 140 kg

Thanks to its closed frame geometry, the Avantgarde DS exhibits very rigid and sporty driving characteristics.

1	Side panel with clothing guard	9	Drive wheel with handrim
2	Seat/seat pad	10	Release button for quick-release axle
3	Front frame	11	Rear frame
4	Scissor wheel lock	12	Drive wheel adapter
5	Crossbrace	13	Back support tube
6	Single-panel foot plate	14	Push handle
7	Caster fork	15	Back support/back support upholstery
8	Caster wheel		

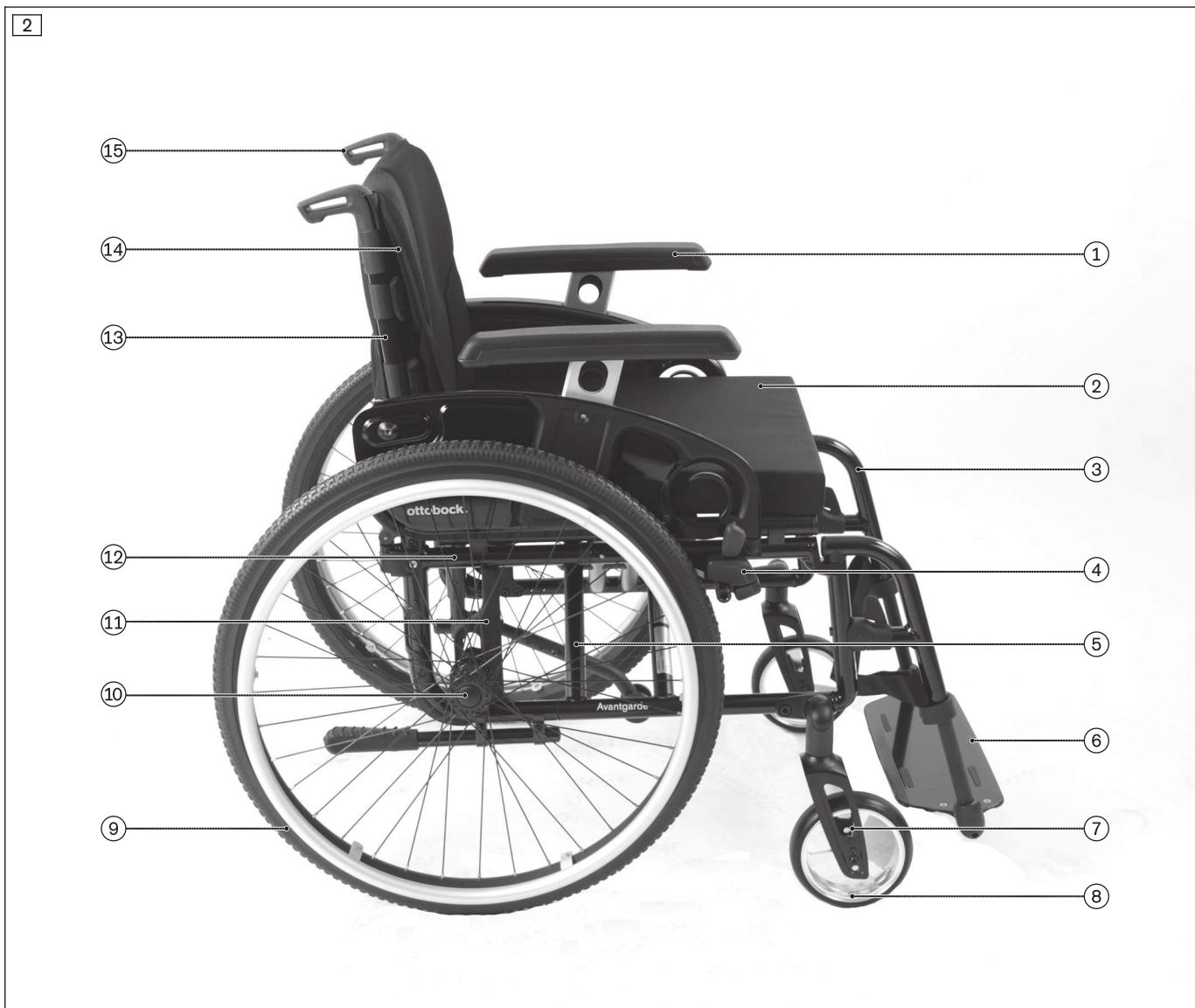

**Avantgarde DV**

**Maximum load** (in combination with double crossbrace): 140 kg

Thanks to its frame geometry, the Avantgarde DV offers precise leg guidance with the possibility of swinging away and removing the leg supports. When the leg supports are removed, the upright frame front section allows the wheelchair to be manoeuvred close to objects.

1	Side panel with arm support/arm pad	9	Drive wheel with handrim
2	Seat/seat pad	10	Release button for quick-release axle
3	Front frame with removable, swing-away leg support	11	Drive wheel adapter
4	Knee lever wheel lock	12	Rear frame
5	Crossbrace	13	Back support tube
6	Single-panel foot plate	14	Back support/back support upholstery
7	Caster fork	15	Push handle
8	Caster wheel		

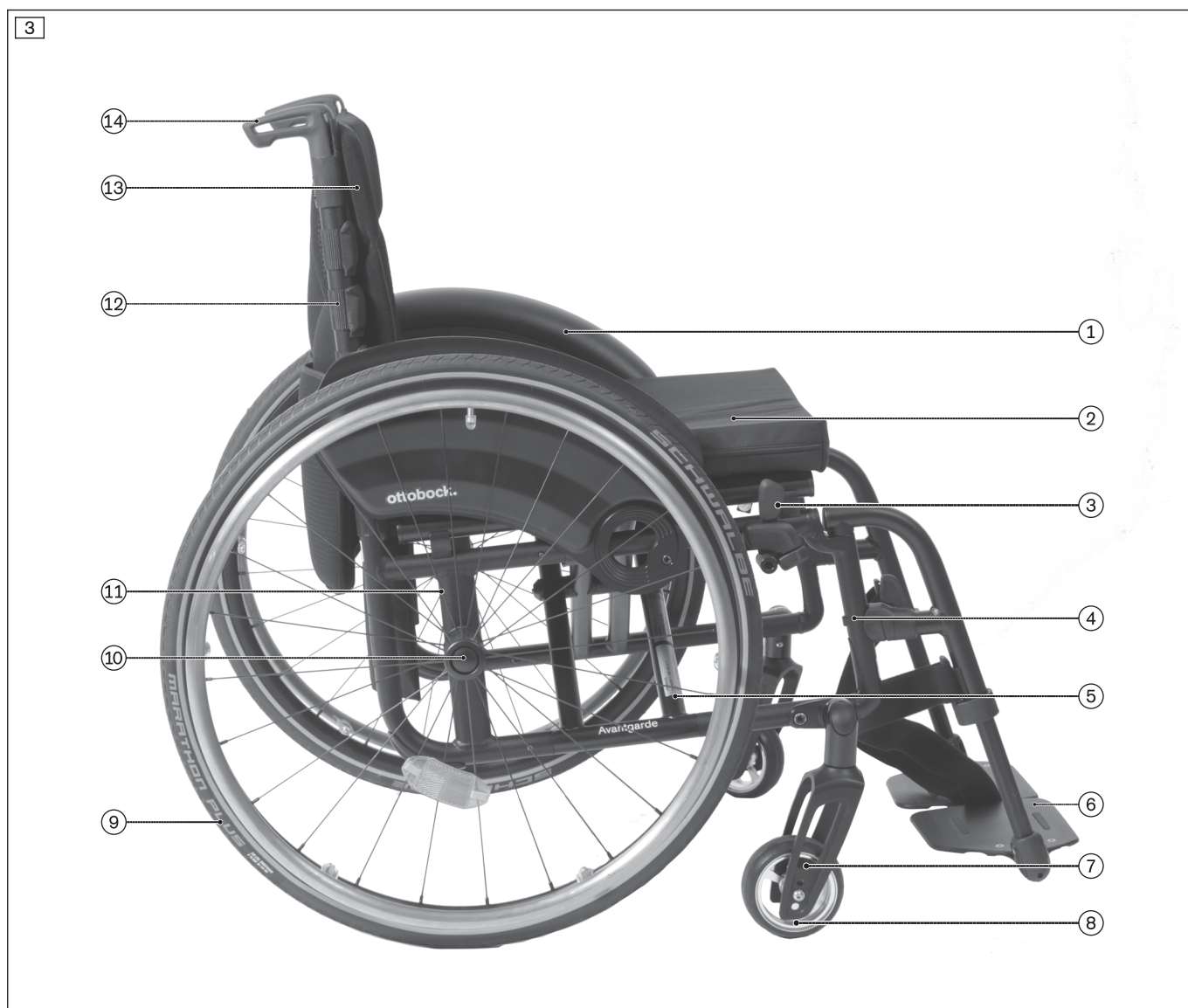

**Avantgarde CLT**

**Maximum load** (in combination with single crossbrace): 100 kg

The Avantgarde CLT is the weight-optimised sports version for particularly active users. In the version CLT "welded", subsequent modification of the wheel position and back support height was sacrificed in favour of saving additional weight.

1	Side panel	8	Caster wheel
2	Seat/seat pad	9	Drive wheel with handrim
3	Knee lever wheel lock	10	Quick-release axle release button
4	Front frame with removable, swing-away leg support	11	Rear frame with permanently welded drive wheel attachment device
5	Crossbrace	12	Back tube
6	Foot plate (here segmented foot plate, aluminium)	13	Back support/back support upholstery
7	Caster fork	14	Push handle



## 3 Intended use

The safe use of the product can only be ensured in case of intended use in accordance with the information contained in these instructions for use. The user is ultimately responsible for accident-free operation.

### 3.1 Indications for use

The wheelchair is intended for everyday indoor and outdoor use, by the user or an attendant, of people with temporary or permanent limitations of the ability to walk, inability to walk or difficulty standing up.

The product is suitable for users with intact skin whose anatomy (such as body dimensions and weight) permits the intended use of the product.

The wheelchair may only be used with the options listed on the product order form.

Ottobock assumes no liability for combinations with medical devices and/or accessories from other manufacturers outside the modular system.

Combinations based on a combination agreement that have been evaluated for effectiveness and safety are an exception to this.

#### 3.1.1 Special features of the CLT and CLT Ultra options

When fitted with the CLT option, the wheelchair features a permanently welded drive wheel adapter for mounting the drive wheel; when fitted with the CLT Ultra option, the wheelchair additionally features a permanently welded back. In these weight-saving versions, the drive wheel and back height cannot be subsequently adjusted. Furthermore, installation of certain options (e.g. anti-tipper) is not possible with these versions.

For these reasons, these wheelchair versions are intended only for experienced users with sporting ambitions who, thanks to their physiological capabilities, are able to handle the wheelchair proficiently. Before supplying one of these versions, the user should be examined intensively for suitability (adequate physiological capabilities).

### 3.2 Indications

- Minor to pronounced or complete restrictions of mobility

### 3.3 Contraindications

#### 3.3.1 Absolute Contraindications



- None known

#### 3.3.2 Relative Contraindications

- Failure to meet physical or mental requirements

## 4 Safety

### 4.1 Explanation of warning symbols

 <b>WARNING</b>	Warning regarding possible serious risks of accident or injury.
 <b>CAUTION</b>	Warning regarding possible risks of accident or injury.
 <b>NOTICE</b>	Warning regarding possible technical damage.

### 4.2 Safety instructions for use

#### Hazards during preparation for use

 <b>WARNING</b>
<b>Independent modification of settings</b>
Serious injuries to the user due to improper changes to the product
<ul style="list-style-type: none"> <li>▶ Do not modify the settings established by the qualified personnel. Only the settings described in the section "Use" in these instructions for use may be adjusted independently.</li> <li>▶ In case of problems with the settings, please contact the qualified personnel who adjusted your product.</li> </ul>

**⚠ WARNING**

**Settings outside the safety limits**

Tipping over, falling due to adjustment errors because of failure to observe the physical/psychological requirements of the user

- ▶ In certain versions and with certain settings, the product tends to tip backwards due to its design. This is an intentional feature designed to enable users with the corresponding physical prerequisites to manoeuvre quickly and nimbly.
- ▶ Users with the necessary physical and psychological preconditions can be supplied with such versions/settings. If the physical/psychological preconditions change, the product may no longer be used with these settings. Inform the responsible qualified personnel immediately in this case.

**⚠ WARNING**

**Improper handling of packaging materials**

Risk of suffocation due to neglect of the duty to supervise

- ▶ Packaging materials must be kept out of the reach of children.

**Risk of hand injuries**

**⚠ CAUTION**

**Pinching on components**

Pinching, crushing due to lack of caution in danger areas

- ▶ Do not reach between the drive wheel and wheel lock or drive wheel and side panel when driving the wheelchair.
- ▶ Do not reach into the spokes of the rotating drive wheel.
- ▶ Pay attention not to pinch parts of your body at the wheel lock lever or between the side or frame parts.

**⚠ CAUTION**

**Heat development when braking with handrims**

Burns due to insufficient hand protection

- ▶ Wear wheelchair gloves when travelling at high speeds.

**Hazards while driving**

**⚠ WARNING**

**Improper use of the wheel lock**

Falling due to abrupt braking, rolling away of the wheelchair, damage to the wheel lock

- ▶ Do not use the wheel lock as a driving brake.
- ▶ Apply the wheel lock to prevent the wheelchair from moving on uneven ground or during transfers (e.g. into a car).

**⚠ CAUTION**

**Lack of driving experience**

Tipping over, falling due to errors in handling the product

- ▶ Practise on level, open ground first.
- ▶ Learn with the support of an assistant how the product reacts to changes in centre of gravity, e.g. downward or upward slopes, inclines or when overcoming obstacles.

**⚠ CAUTION**

**Leaning forward in the wheelchair**

Tipping over, overturning due to incorrect centre of gravity

- ▶ Do not lean too far out of the wheelchair when trying to pick up objects.
- ▶ Lean well forward with your upper body when climbing gradients, overcoming obstacles on gradients or on ramps. If users cannot lean their upper body forward, accompanying persons must support the wheelchair from behind.

**⚠ CAUTION****Risky operation**

Falling, tipping over backwards due to approaching obstacles incorrectly

- ▶ Push slowly when crossing obstacles (e.g. steps, curbs) and negotiating uphill or downhill slopes and inclines.
- ▶ Never cross obstacles at an angle. Always approach obstacles head on (at an angle of 90°).
- ▶ Raise the front wheels before crossing obstacles.
- ▶ Avoid collisions with obstacles and dropping off curbs/ledges.
- ▶ Avoid riding cross-country.

**⚠ CAUTION****Lack of tipping resistance on public transport**

Tipping over, user falls, damage to the product due to incorrect positioning

- ▶ When using public transit, always observe the currently applicable legal requirements and the safety notices of the public transit operator.
- ▶ Use the permanently installed seats in the vehicle. If you depend on using your wheelchair as a seat, please use the designated wheelchair spaces and safety securing equipment provided. Always ensure that you are held in place securely.

**⚠ CAUTION****Incorrect handling at level crossings**

User may fall or tip over due to driving error

- ▶ Only cross railway systems and railway tracks in the designated areas.
- ▶ Negotiate level crossings so the caster wheels of the product cannot get caught in the gap between the rail and the road surface.

**⚠ CAUTION****Driving in the dark**

Risk of collisions with other traffic participants due to lack of lighting

- ▶ Wear bright clothing or clothing with reflectors.
- ▶ Install active lighting on your product.
- ▶ Ensure that the reflectors on the product are clearly visible.

**Hazards when overcoming obstacles****⚠ WARNING****Overcoming steps and obstacles without assistance**

Tipping over, falling of the user due to failure to observe transportation instructions

- ▶ Always have accompanying persons help you negotiate steps and other obstacles.
- ▶ Use available facilities (e.g. access ramps or lifts).
- ▶ If such facilities are not available, have 2 assistants carry you over the obstacle.

**⚠ WARNING****Improper lifting by attendants**

Tipping over, falling of the user due to lifting by removable components

- ▶ Only lift the product by firmly mounted components (e.g. main frame, push handles).
- ▶ Be sure that the clamping levers of the height-adjustable push handles are firmly tightened.

**⚠ WARNING**

**Reduced ground clearance with the "foot-propelled chair" option**

Tipping over, falling due to getting caught on obstacles

- ▶ Please note that wheelchairs with the "foot-propelled wheelchair" option might fall below the minimum ground clearance of **40 mm** depending on the selected settings for the lower leg length and the front seat height.
- ▶ Adjust your driving to the reduced ground clearance and exercise particular caution with obstacles on the ground e.g. steps, curbs and thresholds.

**Hazard in case of broken skin**

**⚠ CAUTION**

**Skin damage**

Skin damage or pressure points due to overloading

- ▶ Check your skin for intactness before and during use of the product.
- ▶ Pay attention to diligent skin care and pressure redistribution during interruptions in using the product.
- ▶ If skin damage or other problems occur during use, stop using the product. Consult the qualified personnel.

**Hazards due to fire, heat and cold**

**⚠ CAUTION**

**Extreme temperatures**

Hypothermia or burns due to contact with components, failure of components

- ▶ Do not expose the product to any extreme temperatures (e.g. direct sunlight, sauna, extreme cold).
- ▶ Do not leave the product in the immediate vicinity of heaters.

**Hazards due to improper use of the product**

**⚠ WARNING**

**Overloading**

Severe injuries if the product tips over due to overloading, damage to the product

- ▶ Do not exceed the maximum load capacity (see the nameplate and section "Technical data").
- ▶ Please note that certain accessories and add-on components will reduce the remaining load capacity.

**⚠ WARNING**

**Exceeding the service life**

Serious injuries due to failure to observe the manufacturer's requirements

- ▶ Using the product beyond the specified expected service life leads to increased residual risk.
- ▶ Observe the specified service life.

**⚠ WARNING**

**Incorrect pushing or pulling of the wheelchair**

Risk of falling, tipping over due to user error

- ▶ Only the push handles may be used for pushing or overcoming obstacles. The tip-assist should be used in addition.
- ▶ If a stabiliser bar is installed, it must **not** be used for pulling or pushing.
- ▶ The attendant should make sure that he/she has a secure stance and firm grip (on both sides).
- ▶ In case of damage, have the push handles repaired promptly.

**⚠ CAUTION**

**Use of the product during diagnostic examinations and therapeutic treatment**

Impairment of the examination results or the effectiveness of treatment due to interactions of the product with devices that are used

- ▶ Make sure that examinations and treatments are carried out exclusively under the prescribed conditions.

**CAUTION**

**Uncontrolled driving behaviour, unexpected sounds or odours**

Falling, tipping, collision with persons or nearby objects due to defects

- ▶ If any faults, defects or other hazards that can lead to personal injury are detected, the product must be taken out of service immediately. This includes uncontrolled movements as well as sounds that are unexpected or previously not noted or odours that deviate significantly from the state of the product at the time of delivery.
- ▶ Contact the qualified personnel.

**NOTICE**

**Use under incorrect environmental conditions**

Damage to product due to corrosion or abrasion

- ▶ Do not use the product in salt water.
- ▶ Make sure that the wheel bearings are not damaged by sand or other particles.

**4.3 Side effects**

The following side effects may occur during use of the product:

- Neck, muscle and joint pain
- Circulatory disorders, risk of pressure sores

Contact a doctor or therapist in case of problems.

**4.4 Further information**

**INFORMATION**

The serial number required for enquiries and orders can be found on the nameplate. For explanations of the nameplate, see the section "Nameplate" (Nameplate).

**INFORMATION**

Even in the event of compliance with all applicable guidelines and standards, alarm systems (e.g. in department stores) may respond to your product. Should this happen, remove your product from the area where the alarm was triggered.

**4.5 Nameplate and warning labels**

The nameplates are found on the crossbrace.

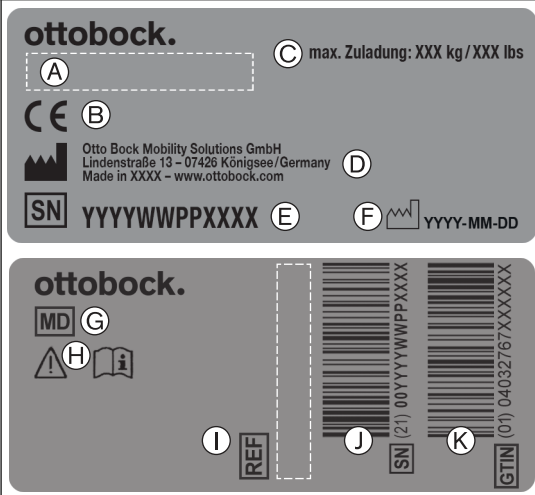
Label	Meaning
	<b>A</b> Manufacturer's product name
	<b>B</b> CE marking
	<b>C</b> Maximum load (see section "Technical data")
	<b>D</b> Manufacturer information/address
	<b>E</b> Serial number <sup>1)</sup>
	<b>F</b> Manufacturing date <sup>2)</sup>
	<b>G</b> Symbol for medical device
	<b>H</b> <b>WARNING!</b> Read the instructions for use before using the product. Observe important safety-related information (e.g. warnings, precautions).
	<b>I</b> Manufacturer's reference number for the product variant
	<b>J</b> Serial number (PI) <sup>3),1)</sup>
<b>K</b> Global Trade Item Number (DI) <sup>4)</sup>	

1) YYYY = year of manufacture; WW = week of manufacture; PP = production site; XXXX = sequential production number

2) YYYY = year of manufacture; MM = month of manufacture; DD = day of manufacture

3) UDI-PI to GS1 standard; UDI = Unique Device Identifier, PI = Product Identifier

4) UDI-DI to GS1 standard; UDI = Unique Device Identifier, DI = Device Identifier

Label	Meaning
	Fixation point to attach the product in vehicles for transporting persons with reduced mobility

## 5 Delivery

### 5.1 Scope of delivery

- Wheelchair ready for use
- Instructions for use (user)
- Instructions for use for accessories (depending on equipment)

### 5.2 Options

The standard model can be fitted to the user's personal requirements thanks to a large range of options. For use of these options: see Page 15 ff.

### 5.3 Storage

#### 5.3.1 Storage during daily use

The wheelchair should always be stored so it is protected against external influences.

#### 5.3.2 Storage during extended disuse

The wheelchair must be stored in a dry place. Specific information for extended storage: see Page 45.

It is not necessary to disassemble or fold up the wheelchair.

Maintain sufficient clearance from sources of heat. If the product is parked for an extended period of time or the tyres overheat (e.g. in the vicinity of radiators or in case of exposure to strong sunlight behind glass), the tyres may become permanently deformed.

During extended storage, the knee lever wheel lock on wheelchairs with PU tyres (= tubeless tyres) must be released since tyre deformation may otherwise result.

## 6 Preparing the product for use

### 6.1 Assembly

#### ⚠ CAUTION

##### Exposed pinch points

Crushing, pinching due to incorrect handling

- ▶ When folding the wheelchair out or together, only grip by the specified components.

#### ⚠ CAUTION

##### Failure to verify readiness for use before putting into operation

Tipping, falling due to incorrect adjustment or installation

- ▶ Before you start using the wheelchair for the first time, check the chosen wheelchair settings with the support of qualified personnel.
- ▶ After every assembly, check for proper mounting of the drive wheels. The quick-release axles must be securely locked in the receiver bushings.
- ▶ Pay particular attention to the stability against tipping, free running of the drive wheels and correct function of the wheel locks.
- ▶ Check the tyre pressure. The correct tyre pressure is printed on the sidewall. Ensure that the pressure is the same in both tyres.

#### INFORMATION

On the topic of disassembly/transport: see Page 35.

It only takes a few simple steps to prepare the wheelchair for use:

- 1) Attach the drive wheels to the quick-release axle mounting (see fig. 4). The quick-release axles must not be removable after releasing the push-button.  
**INFORMATION: With "lock-release assist" option: see Page 25. With "drive wheel for one-handed operation" option: see Page 26.**
- 2) Loosen the safety strap (see fig. 5).
- 3) Unfold the wheelchair (see fig. 6).  
**INFORMATION: While you are next to the wheelchair, tip it slightly toward you and press on the edge of the seat upholstery closest to you.**
- 4) **Only with "drive wheel for one-handed operation" option:** Insert the telescoping rod (see Page 26).
- 5) **If necessary:** Attach the leg supports (see Page 16).  
Fold down the foot plates. When using a single-panel foot plate, be sure the support of the foot plate is locked into the receiver (see fig. 7).
- 6) Fit the seat cushion (see Page 20). The seat cushion is secured against sliding by being pressed onto the hook-and-loop closure.



## 7 Use

### 7.1 Instructions for use

- Attaching loads (e.g. backpacks) can adversely affect stability. Therefore, suspending additional loads on the wheelchair is not permitted.
- The recommended overall width for manual wheelchairs in an operational state is **700 mm**. This specification should ensure unhindered use of escape routes, for example. Please note that the product dimensions can exceed the recommended value in versions with very large seat widths (for more information see see Page 45 ff.).
- The wheelchairs in this series fully satisfy the minimum technical requirements for wheelchairs transportable by train. However, please note that it is possible that not every individual wheelchair will fulfil the minimum requirements due to the variation in designs (please see see Page 46 for further details).

## 7.2 Getting in and transferring

### ⚠ CAUTION

#### Incorrect handling when getting in

Risk of falling, tipping or rolling away due to incorrect handling

- ▶ Activate the wheel lock each time before you get into or out of or transfer to or from the wheelchair.
- ▶ Always get into the wheelchair from the side, where possible.
- ▶ Never step on the foot plates when getting in and out.
- ▶ Do not support yourself on the wheel lock when getting in/out.

Users can choose the method for getting into and out of the wheelchair which is most suitable for them. The respective procedure should be discussed and practised with a therapist.

As a rule, the frame tubes, seat bottom or side panels can be used as supports for getting into the wheelchair.

If getting in independently is not possible, transferring or getting in always has to be performed with the help of an assistant. The manufacturer also offers transfer aids for getting in, such as transfer boards.

## 7.3 Legrests

### ⚠ CAUTION

#### Improper use of the legrests

Tipping over, falling due to errors in handling the product

- ▶ Fold up the footplates before getting in.

### ⚠ WARNING

#### Reduced ground clearance with the "foot-propelled chair" option

Tipping over, falling due to getting caught on obstacles

- ▶ Please note that wheelchairs with the "foot-propelled wheelchair" option might fall below the minimum ground clearance of **40 mm** depending on the selected settings for the lower leg length and the front seat height.
- ▶ Adjust your driving to the reduced ground clearance and exercise particular caution with obstacles on the ground e.g. steps, curbs and thresholds.

The legrests support the user's legs.

The height of the legrest has been adjusted by qualified personnel to the length of the user's lower legs.

The angle of the footrest has been set by the qualified personnel so that it allows the ankles to rest in a comfortable position.

### 7.3.1 Removing and attaching the leg supports

The leg supports of the Avantgarde DV can be removed to make it easier to get in and out as well as for transport.

#### Removing the leg supports – leg support with leg support holder

- 1) Fold the foot plate up (see fig. 8).
- 2) Pull the release lever for the leg support to the side (see fig. 9).
- 3) Swing the leg support out by **90°** and remove it from the leg support retainer (see fig. 10).

#### Attaching the leg supports – leg support with leg support holder

- 1) Hold the leg support **90°** out to the side and insert it into the leg support retainer (see fig. 11).
- 2) Swing the leg support into the direction of travel until it engages (see fig. 10).
- 3) Fold the foot plate down (see fig. 8).





### Removing the leg supports – elevating leg support

- 1) Activate the release lever (see fig. 12, item 1).
- 2) Swing the leg support outwards and to the side by 90° (see fig. 12, item 2) and pull up to detach.

### Attaching the leg supports – elevating leg support

- 1) Hold the leg support 90° out to the side and insert the pivot bearing into the leg support retainer (not pictured).
- 2) Swing the leg support into the direction of travel until it engages.

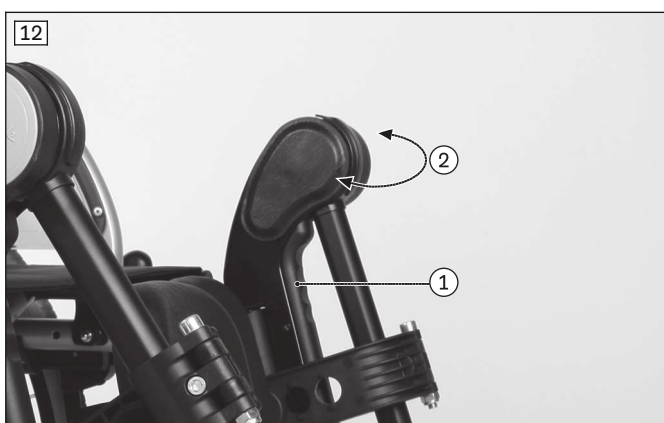

## 7.3.2 Folding the foot plate up and down

### Segmented footplate

- Hold the footplate by the edge and fold it up or down (see fig. 8).

### Folding up and swinging away the single-panel foot plate

- 1) Unhook the foot plate on one side and fold it up to the side (see fig. 13).
- 2) If necessary, the folded up foot plate can also be swung away to the side (see fig. 14).



### Folding down the single-panel foot plate

- ▶ Fold down the foot plate and make sure that the support of the foot plate is locked into the receiver (see fig. 13).

### Additional option "lock for single-panel foot plate"

With this additional option, the foot plate can also be locked in the support (see fig. 15).

Proceed as follows to fold the foot plate up and down:

- 1) Release the lock by pulling on the key ring (see fig. 16). Fold the foot plate up to the side.
- 2) If necessary, the folded up foot plate can also be swung away to the side (see fig. 14).
- 3) Fold down the foot plate and make sure that the foot plate lock engages in the receiver (see fig. 15).



### 7.3.3 Adjusting the angle of the elevating leg support

- 1) Turn the release lever upwards to the stop (see fig. 17).  
**Alternative:** The leg support can also be elevated without operating the release lever.
  - 2) Simultaneously move the leg support to the desired angle.
  - 3) Twist the release lever back down.
- The leg support automatically snaps into place in the next free position (see fig. 18).



### 7.3.4 Removing and fastening the calf strap

The calf strap offers additional support for the user's legs. It also prevents the feet from sliding off the foot plate into the danger area. The calf strap can be removed for cleaning.

#### Fastening the calf strap

- 1) Open all hook-and-loop closures.
- 2) Thread the calf strap through the eyelet on the end piece of the leg support holder and fasten it with hook-and-loop (see fig. 20, see fig. 21, item 1).
- 3) **Only with segmented plastic foot plates:** Thread the calf strap through the eyelet on the side of the foot plate and fasten it with hook-and-loop (see fig. 21, item 2; see fig. 22).
- 4) **Only with segmented aluminium foot plates:** Fasten the calf strap on the underside of the foot plate with hook-and-loop (not pictured).
- 5) Adjust the length and fasten the hook-and-loop closure (not pictured).

#### Removing the calf strap

- 1) Open all hook-and-loop closures.
- 2) Remove the calf strap.



### 7.3.5 Adjusting the leg supports

Further adjustments may be made only by qualified personnel.

## 7.4 Seat cushion and back upholstery

### ⚠ WARNING

#### Seat cushions and back support pads may ignite

Burns due to user error

- ▶ The seat and back support upholstery as well as seat cushions, padding and covers fulfil the normative requirements for flame resistance. However, they may still ignite if fire is handled improperly or negligently.
- ▶ Keep away from all ignition sources, especially lit cigarettes.

### ⚠ CAUTION

#### Wear of the seat and back upholstery

Loss of functionality due to prohibited continued use

- ▶ Have the seat and back upholstery replaced immediately in case of damage.

The product is equipped with seat and back upholstery. Hook-and-loop fasteners on the seat upholstery are used to attach the seat cushion. The seat cushion ensures pressure relief during use of the wheelchair. It was chosen by qualified personnel according to the needs of the user.

### 7.4.1 Removing and fastening the seat cushion

The seat cushion can be removed from the wheelchair for cleaning.

- 1) Lay the seat cushion onto the seat upholstery and secure it against sliding by pressing it onto the hook-and-loop fastener (see fig. 23).
- 2) To remove, detach the seat cushion from the hook-and-loop fastener on the upholstery.



### 7.4.2 Removing and fastening the back support pad

The back padding can be removed from the wheelchair for cleaning.

#### Removing the back support pad

- 1) Remove the seat cushion.
- 2) Pull the back support pad off the seat upholstery towards the rear (see fig. 24).
- 3) Pull the back support pad off the hook-and-loop straps of the back support upholstery (see fig. 25).

#### Fastening the back support pad

- 1) From the rear, apply the edge of the back support pad to the upper hook-and-loop strap (see fig. 25).
- 2) Fold down the back support pad and secure it to the upholstery straps with hook-and-loop fasteners (see fig. 25).
- 3) Pull the part of the flap that can be fastened forward and attach it to the seat upholstery with the hook-and-loop fastener (see fig. 24).



## 7.5 Backrest

The product can be equipped with a fixed or optionally an angle-adjustable backrest.

## 7.6 Side panels

### ⚠ CAUTION

#### Pinching at the side panels

Pinching, crushing due to lack of caution in danger areas

- ▶ Pay attention not to pinch parts of your body between the side panel or frame parts.

The side panels protect the user and his/her clothing from getting dirty.

If armrests have been installed on the wheelchair, they offer the user additional support for the forearms.

### 7.6.1 Removing the side panels

To make getting into the wheelchair easier and for transportation, the desk side panel can be removed.

### ⚠ CAUTION

#### Incorrect use of the side panel

Health hazard, risk of breakage of the side panel mounting due to incorrect use

- ▶ Fold the side panel down such that it engages audibly in the side panel mounting.

### INFORMATION

When using desk side panels in combination with an angle-adjustable back support, the back support angle can only be adjusted from **+3° to -15°**.

### Folding back/removing

- 1) Press the release lever of the desk side panel (see fig. 26).
- 2) Fold up the desk side panel by approx. **90°**.
- 3) Turn the desk side panel towards the back support and pull it out of the side panel mounting (see fig. 27).



### Attaching/closing

- 1) Turn the desk side panel towards the back support and insert it into the side panel mounting (see fig. 27).
- 2) Rotate the desk side panel parallel to the seat surface and fold it down.
- 3) Ensure that the desk side panel engages audibly in the mounting on the frame tube.

### 7.6.2 Adjusting the height of the forearm support

The arm support height on the desk side panel can be changed without the use of tools.

- 1) Pull the release lever in the round opening of the side panel upwards.
- 2) Slide the arm support to the desired position.
- 3) Let go of the release lever. The arm support locks into place automatically.

### 7.6.3 Removing the separate "swing away arm support" with padding

To make getting in and transporting the wheelchair easier, the armrests can be folded away or removed.

- 1) Pull the armrests up out of the holders (see fig. 28).
- 2) Fold the armrests away by 90° (see fig. 29) or remove them.
- 3) After getting in, slide the armrests down into the holders again.



### 7.6.4 Adjusting an arm support with swivel unit

#### INFORMATION

After adjusting the swivel unit, please always make sure that the lock pins have safely snapped in place.

The swivel unit allows the support angle and the rotation setting of an arm support to be adjusted individually.

#### Adjusting the support angle

- 1) Pull the release button outwards (see fig. 30, item 1).
- 2) Lift up the arm support at the front end and adjust it to the desired angle (see fig. 30, item 2).
- 3) Let go of the release button. The arm support will be secured in its position.

#### Adjusting the rotation setting in 15° increments

- 1) Pull the release button downwards (see fig. 31, item 1).
- 2) Move the arm support to the desired rotation setting (see fig. 31, item 2).
- 3) Let go of the release button. The arm support will be secured in its position.

#### Continuously adjusting the rotation setting

- 1) Pull the release button downwards (see fig. 31, item 1).
- 2) Turn the release button 90° (not pictured). The arm support can be rotated freely in this position.
- 3) Move the arm support to the desired rotation setting (see fig. 31, item 2).
- 4) Let go of the release button. The arm support will be secured in its position.

#### Adjusting the depth of the arm support

- 1) Loosen the Allen head screws under the arm support (not pictured).
- 2) Slide the arm support to the desired depth.
- 3) Re-tighten the Allen head screws under the arm support.

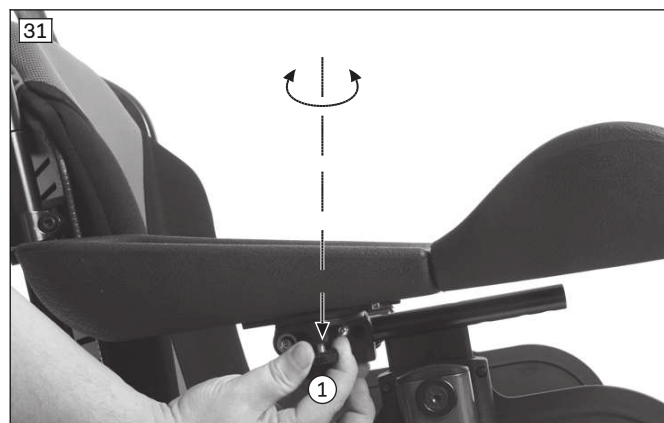

## 7.7 Push handles

The push handles make pushing the wheelchair easier for the attendant.

Some of the push handle designs allow the height to be adjusted to suit the needs of the attendant.

### 7.7.1 Adjusting the height of the push handles

To enable ergonomic pushing by the attendant, the wheelchair can be equipped with height-adjustable push handles.

- 1) Release the clamping lever.
- 2) Adjust the height of the push handle.

**INFORMATION: Adjust both push handles to the same height.**

- 3) Engage the clamping lever.



### 7.7.2 Removing the push handles

Push handles of the “height-adjustable, removable” type can be removed from the back support tube when needed.

#### Removing/installing the push handles

- 1) Release the clamping lever (see fig. 34, item 1).
  - 2) Push in the tripod spring (see fig. 34, item 2) and pull the push handle up and out of the adapter (see fig. 34, item 3).
  - 3) To install, push in the tripod spring again and insert the push handle into the adapter.
  - 4) Firmly close the clamping lever (see fig. 34, item 1).
- Both push handles must be installed at the same height.



## 7.8 Stabiliser bar

The stabiliser bar between the push handles increases the wheelchair's stability, especially in case of high loads (see fig. 35). It has to be opened before folding the wheelchair.

**Please note:** Using the stabiliser bar for pushing and pulling the wheelchair is not permitted. Always use the push handles for this purpose.

### Opening the stabiliser bar

- 1) Open the star handle on the right side (see fig. 36, item 1).
- 2) Fold the stabiliser bar down (see fig. 36, item 2).

### Closing the stabiliser bar

- 1) Fold the stabiliser bar up until the opening is against the screw of the star handle.
- 2) Hand-tighten the star handle.



## 7.9 Drive wheels

### ⚠ WARNING

#### Improper assembly of removable wheels

Tipping, falling over of the user due to wheels coming off

- ▶ After each assembly, verify the proper fit of the removable wheels. The quick-release axles must be firmly locked in the wheel attachment.

### ⚠ WARNING

#### Defective tyres

Accidents/falling due to poor traction, reduced braking force or lack of manoeuvrability

- ▶ Maintain sufficient tyre pressure. Note the information in the section "Technical data" or on the tyre sidewall.
- ▶ Ensure that the pressure is the same in both tyres.
- ▶ Ensure that the tyres have sufficient tread depth.



**⚠ CAUTION****Reaching into exposed drive parts**

Crushing, pinching due to incorrect handling

- ▶ Do not reach between the drive wheel and wheel lock or drive wheel and side panel when driving the product.
- ▶ Do not reach into the spokes of the rotating drive wheel while riding in the product.

**⚠ CAUTION****Heat development when braking with handrims**

Burns due to insufficient hand protection

- ▶ Wear wheelchair gloves when travelling at high speeds.

The wheelchair is moved, steered, braked and stopped with the help of the handrims on the drive wheels.

To make transport easier, drive wheels with quick-release axle can be taken off the wheelchair.

**7.9.1 Removing and mounting the drive wheels****⚠ CAUTION****Incorrect removal/attachment of the wheels**

Tipping, falling due to incorrect installation

- ▶ The user is not permitted to sit in the wheelchair during wheel replacement.
- ▶ For changing wheels, set the wheelchair onto a solid surface.
- ▶ To change the wheels, secure the wheelchair against tipping over or rolling away.
- ▶ If the drive wheel does not lock securely or has too much sideways play, contact the qualified personnel promptly.

**Rear wheels with quick-release axle**

- 1) Release the wheel lock.
- 2) Grip the area between the spokes near the hub with your fingers.
- 3) Use your thumb to press in the push-button on the quick-release axle.
- 4) Remove or mount the drive wheel.

**After mounting:** The drive wheels must not be removable after releasing the push-button on the quick-release axle.

**Drive wheels with lock-release assist**

The quick-release axle with lock-release assist for people with quadriplegia makes it possible to install the drive wheels even in case of severely limited mobility of the arms and hands.

- 1) Open the lock-release assist according to the handle position (see fig. 39: locked – handle is parallel to wheel hub; see fig. 40: unlocked – handle is perpendicular to wheel hub). The lock is released when the handle is positioned horizontally (90° position).
- 2) Pull off/push on the drive wheel.

- 3) Close the lock-release assist (see fig. 39: locked – handle is parallel to wheel hub; see fig. 40: unlocked – handle is perpendicular to wheel hub).

**INFORMATION: The wheels must fit in to the wheel attachment device without there being any play after closure.**

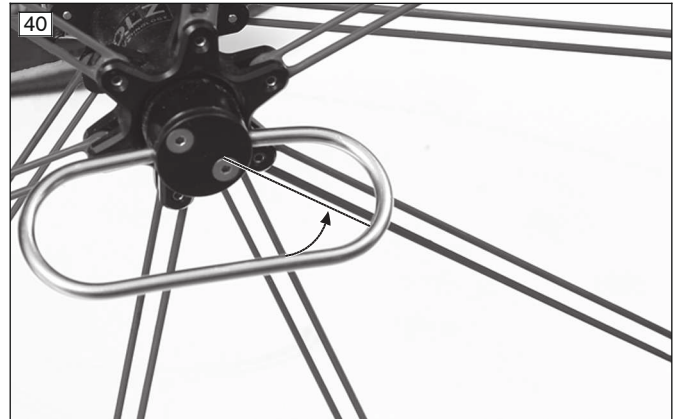
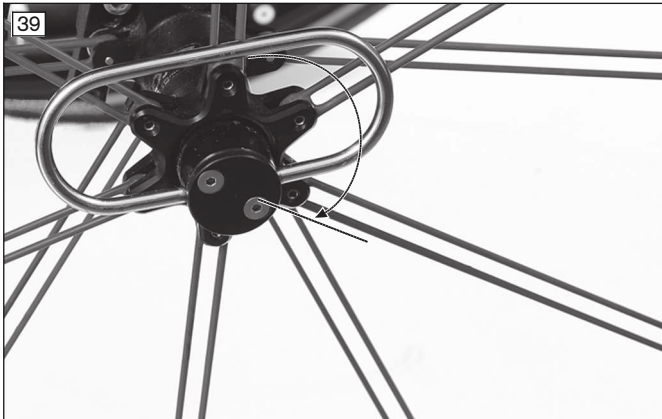

### 7.9.2 Rear wheel with one-handed operation (double push rings)

The wheel set for one-handed operation allows hemiplegics or unilateral amputees for example to operate the wheelchair with one hand (see fig. 41).

- **Using the outer and inner handrim together:** Both wheels are driven together. The wheelchair drives straight ahead.
- **Using only the outer handrim:** Only the drive wheel is moved. The wheelchair can be steered with forward, stopping or backward movements of the handrim.

The one-hand drive is supplied with special quick-release axle mountings and a telescoping rod.

#### Using drive wheels for one-handed operation

- 1) Use your thumb to press the push-button on the quick-release axle.
- 2) Install the drive wheels for the one-hand drive in the quick-release axle mountings (see fig. 42) and lock them by turning the locking bolt 90° (see fig. 43).
- 3) The quick-release axles must not be removable after releasing the push-button.
- 4) Insert the telescoping rod. To do so, set one side of the telescoping rod onto the wheel pivot protruding from the inside of the quick-release axle mounting (see fig. 44).
- 5) Compress the telescoping rod and set the other end of the rod onto the second wheel pivot.

#### Removing drive wheels for one-handed operation

- 1) Compress the telescoping rod and remove it (see fig. 44).
- 2) Open the locking mechanism on the quick-release axle. To do so, turn the locking bolt by 90° (see fig. 43).
- 3) Use your thumb to press the push-button on the quick-release axle and remove the drive wheel.





## 7.10 Caster wheels and caster forks

### ⚠ WARNING

#### Failure of caster wheels or caster forks

Falling, severe injury due to the wheelchair tipping over

- ▶ Regularly inspect the caster wheels and caster forks for damage.
- ▶ Regularly clean and oil the caster wheel axles and the threaded axles on the caster forks, especially in case of stiffness.
- ▶ Inform the responsible qualified personnel in case of permanent changes to the driving characteristics.

### ⚠ CAUTION

#### Incorrect caster wheel position when leaning forward in the wheelchair

Tipping over, falling due to incorrect caster wheel positioning

- ▶ Prior to activities that require you to bend forward in the wheelchair (e.g. tying your shoes), maximise the stability of the wheelchair.
- ▶ In order to do so, push the wheelchair backwards until the caster wheels turn forward.

The combination of caster wheels and caster forks ensures the ability to hold a straight line and navigate bends securely.

The caster wheels and caster forks have been chosen by the qualified personnel according to the needs of the user.

### 7.10.1 Approach in case of stiffness

#### NOTICE

#### Using sharp or pointed objects

Damage to the caster wheels or caster forks

- ▶ Do not use pointed or sharp objects when removing dirt.

In case of stiffness, the caster wheel axles should be cleaned and oiled.

#### Oiling the caster axle

- 1) Remove dirt (such as hairs) from the caster axle between the caster wheel and caster fork.
- 2) Lubricate the caster axle between the caster wheel and caster fork with a few drops of thin, resin-free oil (sewing machine oil).

## 7.11 Wheel locks

The wheel locks secure the parked wheelchair against rolling away.

The drum brakes allow the attendant to slow the wheelchair easily and safely by activating the wheel lock lever on the push handles.

### 7.11.1 Using the wheel locks

#### **⚠ WARNING**

#### **Improper use of the wheel lock**

Falls due to abrupt braking, rolling away of the product, crushing of hands

- ▶ Do not use the wheel lock as a driving brake.
- ▶ Always engage the wheel lock on both sides.
- ▶ Engage the wheel lock to prevent the product from moving when it is parked on uneven ground or during transfers (e.g. into a car).
- ▶ Do not reach between the rear wheel and the wheel lock when driving the product.
- ▶ Ensure that the knee lever wheel lock is properly adjusted (max. **5 mm** gap to the tyre). The lock bolt must lock the drive wheel securely when stationary.
- ▶ Please contact the qualified personnel who adjusted your product for readjustment of the wheel lock.

#### **Activating/deactivating the knee lever wheel lock**

- 1) Push the handle of the knee lever wheel lock forward (see fig. 45, item 1; version with wheel lock lever extension: see fig. 46, item 1).  
→ The wheel lock bolt secures the wheel.
- 2) Pull the handle of the knee lever wheel lock up (see fig. 45, item 2; version with wheel lock lever extension: see fig. 46, item 2).  
→ The wheel lock bolt releases the wheel.

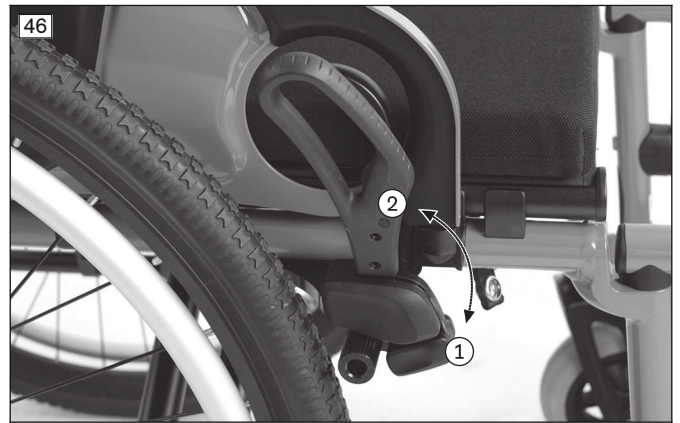
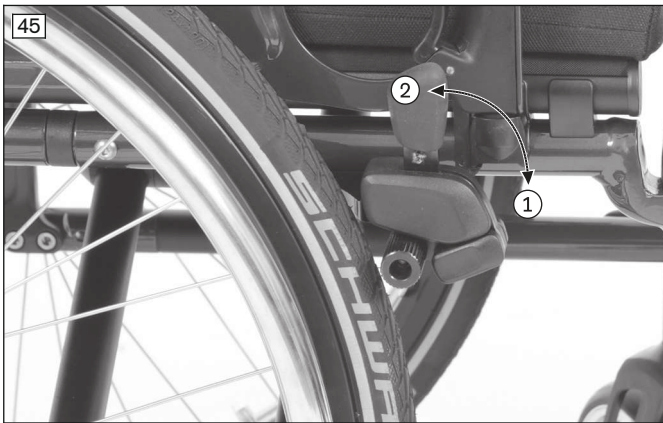

#### **Activating/deactivating the scissor wheel lock**

- 1) Reach under the seat and pull the handle of the scissor wheel lock towards the back from the side (see fig. 47).  
→ The wheel lock bolt secures the wheel.
- 2) Pull the handle of the scissor wheel lock forwards to unfold (see fig. 48).  
→ The wheel lock lever releases the wheel.



### Activating/deactivating the knee lever wheel lock for one-handed operation

This wheel lock is recommended especially for hemiplegics. It can be activated either on the right or left side and ensures the safe locking of both rear wheels with a pull-wire system.

#### INFORMATION

Note that the wheel lock lever extension must always be attached when releasing or engaging the wheel lock.

- 1) Push the handle of the knee lever wheel lock forward (see fig. 49, item 1).  
→ The wheel lock bolt secures the wheel.
- 2) Pull the wheel lock lever upwards (see fig. 49, item 2).  
→ The wheel lock lever releases the wheel.



### 7.11.2 Drum brake

The drum brakes allow the attendant to slow the wheelchair easily and safely by activating the wheel lock lever on the push handles.

#### Activating/deactivating the drum brake

- 1) Pull the brake lever (see fig. 50, item 1).
  - 2) If necessary, secure the brake lever by additionally actuating the lock slide (see fig. 50, item 2).
  - 3) Deactivate the brake by actuating the brake lever again or pressing the lock slide.
- The drive wheels can still be removed via the quick-release axles when the brake lever is released.



### 7.11.3 Knee lever wheel lock for user and attendant

This wheel lock type can be used by both the user and an attendant.

#### INFORMATION

- ▶ Operation of the wheel lock by the user is the same as for the knee lever wheel lock described above.
- ▶ Operation of the wheel lock levers by the attendant is the same as for the drum brake described above.

#### Activation/deactivation by the user

- 1) Push the handle of the knee lever wheel lock forward (see fig. 51, item 1).

- The wheel lock bolt secures the wheel.
- 2) Pull the wheel lock lever upwards (see fig. 51, item 2).
  - The wheel lock bolt releases the wheel.

**Activation/deactivation by the attendant**

- 1) Pull the brake lever (see fig. 50, item 1).
  - The wheel lock bolt secures the wheel.
- 2) Secure the wheel lock lever by additionally actuating the lock slide (see fig. 50, item 2).
  - The wheel lock bolt secures the wheel.
- 3) Deactivate the wheel lock by actuating the brake lever again or pressing the lock slide (see fig. 50, item 1/2).
  - The wheel lock bolt releases the wheel.



**7.11.4 Using the plug-on wheel lock lever extension**

The “plug-on wheel lock lever extension” option makes the knee lever wheel lock easier to use. The wheel lock lever extension can be removed for easier transfer into the wheelchair. The wheel lock lever extension is attached to the wheel lock lever with a rubber band.

**Removing/mounting the wheel lock lever extension**

- 1) Pull the handle of the wheel lock lever extension forward or up, away from the wheel lock lever (see fig. 52, left).
- 2) Fold the wheel lock lever extension either forward (see fig. 52, right) or to the side (see fig. 53).
- 3) To mount, pull on the handle of the wheel lock lever extension and slide the wheel lock lever extension back onto the wheel lock lever.



## 7.12 Anti-tipper/tip-assist

### ⚠ WARNING

#### Anti-tipper not activated

Tipping over, falling of the user due to improper operation of a safety device

- ▶ Ensure that an installed anti-tipper is activated before travelling over obstacles and on inclines.
- ▶ The anti-tipper has to engage audibly prior to use. Proper engagement must be checked by the user or an attendant.
- ▶ The use of an anti-tipper is highly recommended for transfemoral amputees and inexperienced users.

### ⚠ WARNING

#### Incorrectly adjusted anti-tipper

Tipping over, falling of the user due to errors in handling the product

- ▶ If only one attendant helps in overcoming steps, the attendant must first deactivate the anti-tipper so that it cannot collide with the steps during transport.
- ▶ The attendant must activate the anti-tipper again after overcoming the steps.

### ⚠ WARNING

#### Incorrectly adjusted anti-tipper

Risk of falling as a result of incorrectly adjusted anti-tipper.

- ▶ The anti-tipper may only be adjusted by qualified personnel.

The anti-tipper prevents the wheelchair from tipping backwards when overcoming obstacles and going uphill. It is set for a maximum ground clearance of **50 mm** and so that the anti-tipper rollers, as a minimum, project fully beyond the largest diameter of the drive wheels.

The tip-assist makes overcoming obstacles easier for the attendant.

### 7.12.1 Activating and deactivating the anti-tipper

A mounted anti-tipper must always be active.

When overcoming obstacles (such as steps and curbs that are not lowered) **upwards**, the anti-tipper rollers contact the ground.

When overcoming obstacles (such as steps and curbs that are not lowered) **downwards**, the anti-tipper has to be deactivated by the user or attendant to avoid damaging the anti-tipper.

#### Activation

- 1) Push the anti-tipper down with the hand or foot (see fig. 54).
- 2) Swing the anti-tipper back and allow it to engage (see fig. 55).

#### Deactivation

- 1) From above, press on the anti-tipper with the hand or foot until it disengages (see fig. 56).
- 2) Rotate the anti-tipper forwards by **180°** and release it (see fig. 55).





### 7.12.2 Using the tip-assist

- 1) At an obstacle, place one foot on the tip-assist and push down (see fig. 57).
- 2) The wheelchair can be tipped easily by simultaneously pressing down on the push handles.

### 7.13 Transport wheels

#### ⚠ CAUTION

##### **Knee lever wheel lock when the drive wheels are removed**

Risk of accident, falling due to loss of functionality of the knee lever wheel lock

- ▶ Note that a wheelchair with transport wheels can only be braked by an attendant.

#### ⚠ CAUTION

##### **Incorrect height setting**

Risk of tipping or falling due to the sloped product setting

- ▶ Always adjust the height equally on both sides.

The transport wheels permit movement through very narrow passages (e.g. in trains or aircraft).

Transport wheels take the place of the drive wheels. In order to move, an attendant is required to push the wheelchair.

#### 7.13.1 Using the transport wheels

- > Prior to use, verify whether the transport wheels have been set to the same height. If this is not the case: Press in the locking pin and adjust the height equally on both sides. The locking pin must engage audibly.
- 1) Remove the drive wheels.  
Whenever possible, this should be done when the user is not sitting in the wheelchair. If the user is sitting in the wheelchair, proceed as follows:
  - 2) The first attendant holds the wheelchair in a stable position so that the drive wheels are relieved in turn.
  - 3) The second attendant carefully removes the first and second drive wheel one after the other.
- The wheelchair can now be pushed on the transport wheels.





## 7.14 Lap belt (seat belt)

### **⚠ CAUTION**

#### **Incorrectly adjusted lap belt**

Malpositions, illness, falling of the user due to installation/adjustment errors

- ▶ Do not modify the settings established by the qualified personnel. In case of problems with the adjustments (unsatisfactory sitting position) please contact the qualified personnel who fitted the product.
- ▶ The lap belt has to fit closely but not too tightly so the user is not injured. It should be possible to slide two fingers comfortably between the belt and thigh.
- ▶ Have the settings of the belt system checked regularly. Adjustments may be required due to the growth of the user or because of changes in the course of the disease or different clothing.

The lap belt (seat belt) prevents the user from slipping and supports positioning.

It is installed on the product by qualified personnel if needed and adapted to the requirements of the user.

Information about subsequent acquisition and mounting is provided by the qualified personnel that handed over the product.

#### **Using the lap belt**

- 1) Open the buckle.
- 2) Place the user in an upright, 90° seated position (if physiologically possible). Ensure that the back is up against the back support pad (if physiologically possible).
- 3) Close the buckle.
- 4) The lap belt should be at an angle of about 60° to the seat bottom. The belt strap should run across the thighs in front of the pelvic bones (see fig. 60).

#### **Possible errors**

- The lap belt is positioned above the user's pelvis in the area of the soft part of the stomach.
- The user does not sit upright in the seat.
- If the lap belt is too loose, the user can shift/slide out to the front.
- During the installation/adjustment, the lap belt is routed over parts of the seating system (e.g. over forearm supports or seat pads). This causes the lap belt to lose its retaining function.

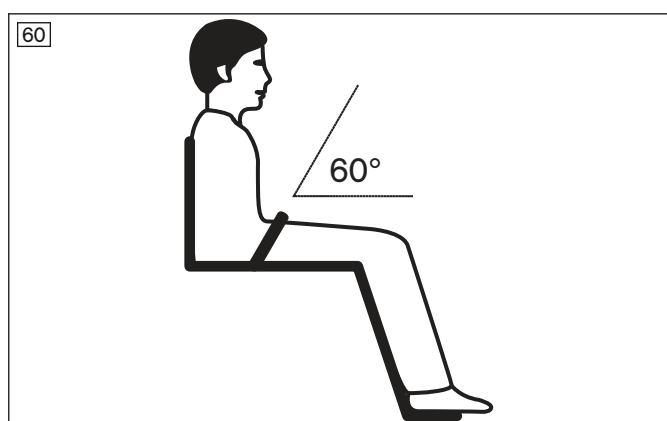

## 7.15 Tray

### **⚠ WARNING**

#### **Inflammable product**

Burns due to user error

- ▶ The product is flame retardant but nevertheless flammable. Therefore the utmost caution must be exercised in the vicinity of an open flame.
- ▶ Keep away from all ignition sources, especially lit cigarettes.

**CAUTION**

**Improper adjustment**

Crushing or pinching due to adjustments which are too tight

- ▶ Do not pinch the user when sliding in the product.

**CAUTION**

**Driving with objects on the tray top**

Injuries due to unsecured objects

- ▶ Remove all objects from the tray top prior to travelling.

**CAUTION**

**Improper lifting by attendants**

Tipping over, user falls due to lifting by removable components

- ▶ The product must not be lifted by the tray.

**NOTICE**

**Overloading**

Damage to the product due to user error

- ▶ Do not load the tray with heavy objects.
- ▶ No persons may sit or lean on the tray.

The tray serves as a supporting surface during meals, when working or when playing. The clear material allows visibility of the legs and correction of the sitting posture.

Prior to use in a vehicle for transporting persons with reduced mobility, the tray has to be removed.

**Mounting/removing the tray**

- 1) Slide the tray on to the armrests.
- 2) Pull the tray off the armrests.

Always guide the tray parallel to the armrests to avoid canting.

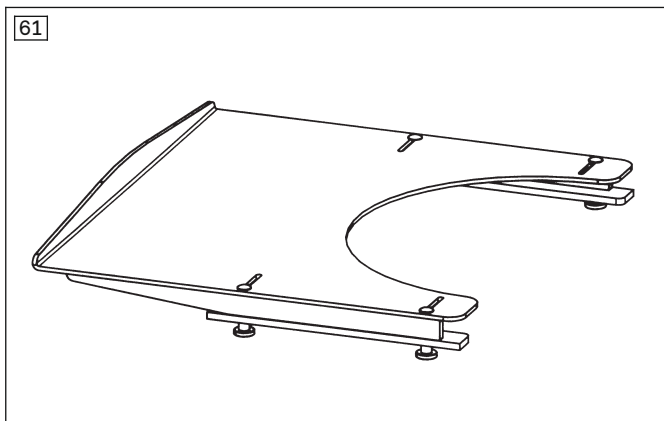

**Mounting/removing the half tray**

- 1) Slide the tray onto the arm support.
- 2) Pull the tray off the arm support.

Always guide the tray parallel to the arm support to avoid canting.



## 7.16 Additional options

The product may be equipped with additional options.

The options are firmly mounted to the product by qualified personnel or the manufacturer and are pre-adjusted by qualified personnel at delivery.

## 7.17 Disassembly and transport

### CAUTION

#### Exposed pinch points

Crushing, pinching due to incorrect handling

- ▶ When folding the wheelchair out or together, only grip by the specified components.

### NOTICE

#### Deformation of the folded backrest

Problems unfolding due to unallowable loads

- ▶ Never rest heavy objects on the backrest when it is folded in.

### INFORMATION

- ▶ When transporting the wheelchair in vehicles, fold it up and remove the wheels and leg supports if necessary.
- ▶ Follow the IATA (International Air Transport Association) rules and those of the relevant airline when transporting the wheelchair in an aircraft. Inform the airline several days before your flight. Use the SSR (special service request) codes to describe the type of limited mobility if necessary. You can for example research these on the Internet.

The wheelchair must be prepared for transport in a passenger vehicle.

- 1) Single-panel foot plate: Fold up and swing away the foot plate to the side (see fig. 7, see fig. 14).  
Segmented foot plate: Fold up both sections (see fig. 8).

**INFORMATION: For the Avantgarde DV the leg supports can also be removed, thus further reducing the packing size (see Page 16).**

- 2) Remove the seat cushion.
- 3) **Only with "drive wheel for one-handed operation" option:** Before folding, remove the telescoping rod (see Page 26).
- 4) Pull up the seat upholstery until the wheelchair folds together (see fig. 64).
- 5) Fasten the safety strap (see fig. 65).
- 6) Insert four fingers between the spokes of the drive wheel and press the knob of the quick-release axle with your thumb. Pull off the drive wheel outwards (see fig. 4).

**INFORMATION: With "lock-release assist" option: see Page 25. With "drive wheel for one-handed operation" option: see Page 26.**



## 7.18 Use in vehicles for transporting persons with reduced mobility

### 7.18.1 Avantgarde DV/DS without CLT and CLT Ultra options

#### **⚠ WARNING**

##### **Use in vehicles for transporting persons with reduced mobility**

Serious injuries in case of accidents due to user error

- ▶ Always use the seats and personal restraint systems in the vehicle for transporting persons with reduced mobility first. This is the only way to ensure optimum protection of passengers in the event of an accident.
- ▶ If the product is to be used as a seat in a vehicle for transporting persons with reduced mobility, the safety elements offered by the manufacturer and appropriate fastening and personal restraint systems must be used. For more information, please refer to our brochure with the order number 646D158.
- ▶ Never transport more than one person in the product.
- ▶ Only use the product in a vehicle for transporting persons with reduced mobility with the back support in a vertical position.
- ▶ Observe the limitations regarding installed options (see Page 39).

#### **⚠ WARNING**

##### **Use of the belt system as a passenger restraint system in vehicles for transporting persons with reduced mobility is forbidden**

Serious injuries due to improper handling of the product

- ▶ Under no circumstances may the belts and positioning aids offered with the product be used as part of a passenger restraint system in vehicles for transporting persons with reduced mobility.
- ▶ Note that the belts and positioning aids offered with the product are only intended to help support the user sitting in the product.

The product has been tested by the manufacturer according to ISO 7176-19 and may be used as a seat in vehicles for transporting persons with reduced mobility subject to the conditions defined below.

The product must be sufficiently secured during transport in vehicles for transporting persons with reduced mobility. The illustrations that follow show an example for anchoring in a motor vehicle.

The manufacturer is not responsible for the fastening systems that are used. Ensure that only fastening systems that meet the applicable legal requirements and are designed for the overall weight of the product including the user are used.

The transport weight of the person to be transported in a vehicle for transporting persons with reduced mobility corresponds to the maximum permissible user weight (see Page 45).

#### **7.18.1.1 Required accessories**

Four belt loops are necessary in order to use the product as a transport seat in a vehicle for transporting persons with reduced mobility (tested according to ISO 10542-1 or comparable test standards). The qualified personnel who fitted the wheelchair can provide more information.

#### **Required materials**

- 4 belt loops (e.g. from Unwin Safety Systems, Q'Straint)

### 7.18.1.2 Using the product in a vehicle

#### **⚠ WARNING**

#### **Positioning in vehicles for transporting persons with reduced mobility**

Serious injuries in case of accidents due to user error

- ▶ Positioning of the product in vehicles for transporting persons with reduced mobility may only be performed by the qualified personnel.
- ▶ The product must always face forwards when it is used as a seat in a vehicle for transporting persons with reduced mobility.
- ▶ Instruct the qualified personnel regarding the mounting points on your product described below.

#### **⚠ WARNING**

#### **Inadequate transportation safety**

Loss of safe restraint due to failure to observe transportation instructions

- ▶ Observe the following instructions for correct transport safety in the vehicle for transporting persons with reduced mobility.
- ▶ If necessary, instruct the qualified personnel on the following information.

#### **Securing the product in the vehicle for transporting persons with reduced mobility**

The wheelchair is secured in the vehicle for transporting persons with reduced mobility with the help of four belt loops, on which the vehicle side wheelchair restraint belts are attached.

The fixation points of the belt loops are marked with stickers (pattern). These stickers show where the user has to pass the belt loops around the frame tube:

- The stickers that label the front fixation points are found on the front frame tube on each side (Avantgarde DV example: see fig. 66, item 1).
- The stickers that label the rear fixation points are found on the rear frame tube on each side (Avantgarde DV example: see fig. 67, item 1).



#### **Attaching the belt loops**

- 1) Position the product in the vehicle for transporting persons with reduced mobility. For more information, please refer to section 5 in the brochure "Transporting persons with reduced mobility", order number 646D158.
- 2) **Front fixation points:** Attach one belt loop around each of the frame tubes on the left and right of the front frame, wrapping them around the frame tubes at the marked position once or twice depending on the length (Avantgarde DS: see fig. 68, item 1; Avantgarde DV: see fig. 69, item 1).
- 3) Engage the hook of the respective vehicle side wheelchair restraint belt in the belt loop (Avantgarde DS: see fig. 68, item 2; Avantgarde DV: see fig. 69, item 2).
- 4) **Rear fixation points:** Attach one belt loop around each of the frame tubes on the left and right, wrapping them around the frame tubes at the marked position (see fig. 70, item 1).
- 5) Engage the hook of the respective vehicle side wheelchair restraint belt in the belt loop (see fig. 70, item 2).
- 6) Tighten the vehicle side wheelchair restraint belts at the front and rear as firmly as possible.
  - Avantgarde DS: The product showing the correct positioning of the attachment straps (see fig. 72).
  - Avantgarde DV: The product showing the correct positioning of the attachment straps (see fig. 73).

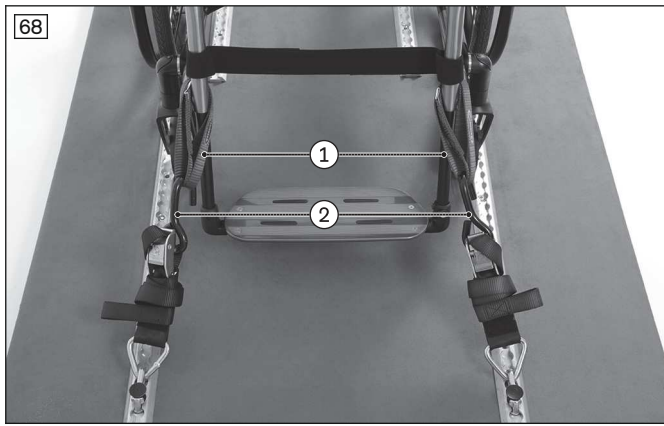

**Information on correct transport safety of the user in the vehicle for transporting persons with reduced mobility**

- Using the personal restraint system of the vehicle for transporting persons with reduced mobility is required. Attaching personal restraint systems of the vehicle for transporting persons with reduced mobility to the wheelchair is not permitted. The 3-point restraint has to be realised entirely on the vehicle:
  - The lap belt of the personal restraint system is usually attached by the qualified personnel to the left and right sides respectively on the mounting point/pin of the rear lashing straps (wheelchair restraint belts on the vehicle bottom).
  - The shoulder belt of the personal restraint system is usually mounted on the vehicle pillar and is attached by the qualified personnel to the corresponding mounting point/pin provided on the lap belt.
- The straps of the personal restraint system must always be routed close to the user's body. The straps must not be routed over the side panels and wheels (see fig. 71 item 2).
- The shoulder belt must always be routed over the user's shoulder (see fig. 71, item 1).
- The belt strap must not be twisted on the user's body.

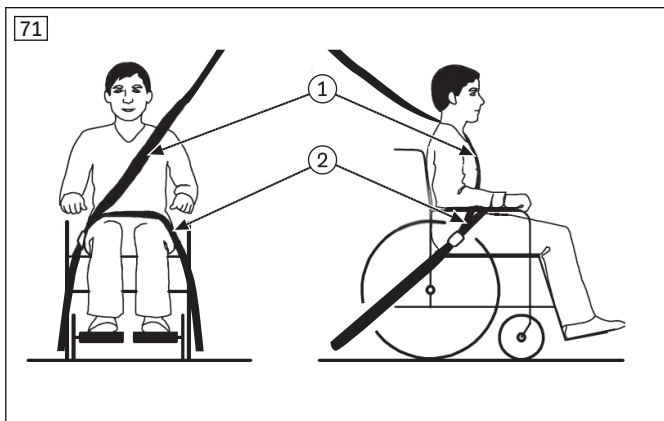

### Placement of the personal restraint system integrated in the vehicle for transporting persons with reduced mobility

- 1) Pull each end of the restraint lap belt from the inner side of the seat through to the outside (see fig. 74).
- 2) Engage the ends of the restraint lap belt on the mounting point/pin of the rear lashing straps on the left and right sides respectively (see fig. 75).
- 3) Secure the shoulder harness on the mounting point/pin provided on the lap belt (not illustrated).
  - The restraint lap belt is pulled through and fastened.
  - The belt runs between the side panel and seat cushion on each side.



#### 7.18.1.3 Restrictions for use

##### **⚠ WARNING**

##### **Risk of accidents and injury due to using the product with certain settings and/or installed options**

Severe injury in case of accidents due to options coming loose

- ▶ Before using the product as a seat in a vehicle for transporting persons with reduced mobility, remove options that need to be taken off for safe transportation. Please observe the following table.
- ▶ Stow all dismantled components securely in the vehicle for transporting persons with reduced mobility.
- ▶ Please note that certain settings on the product exclude the use of the product in a vehicle for transporting persons with reduced mobility.

Option <sup>1)</sup>	Transportation in a vehicle for transporting persons with reduced mobility not possible	Remove option	Secure option on product
Add-on drive	X		
Crutch holder with tip-assist, right/left (Avantgarde DS) Crutch holder (Avantgarde DV)	X		
Wheelbase extension	X		

Option <sup>1)</sup>	Transportation in a vehicle for transporting persons with reduced mobility not possible	Remove option	Secure option on product
Angle-adjustable back support	X		
Back support height < 400 mm	X		
Shock absorber	X		
Transport wheel			X <sup>2)</sup>
Tray		X	
Lap belt			X <sup>3)</sup>

<sup>1)</sup> Not all of the options named are installed on all products.

<sup>2)</sup> Transport wheels can remain on the wheelchair with installed drive wheels during transportation in a vehicle for transporting persons with reduced mobility.

<sup>3)</sup> The lap belt can be used to position the passenger during transportation. Using the personal restraint system is nevertheless required.

### 7.18.2 CLT and CLT Ultra options

#### WARNING

##### **Improper use in vehicles for transporting persons with reduced mobility**

Risk of serious injury when using the product as a seat

- ▶ The product has **not** been approved by the manufacturer for use as a seat in vehicles for transporting persons with reduced mobility.
- ▶ In vehicles for transporting persons with reduced mobility, only use the seats installed in the vehicle with the corresponding personal restraint systems.
- ▶ Information on the current status of our measures is available from the qualified personnel.

The Avantgarde CLT and Avantgarde CLT wheelchairs have not been approved by the manufacturer for use as a seat in vehicles for transporting persons with reduced mobility.

### 7.19 Care

#### CAUTION

##### **Lack of or improper cleaning**

Health hazard due to infections, damage to the product due to user error

- ▶ Clean the product at regular intervals.
- ▶ Do not clean the product with a jet of water or a pressure washer. The penetration of water can cause corrosion and subsequent malfunctions.
- ▶ To avoid contamination with germs, clean seat cushions and back support upholstery whenever they get soiled.
- ▶ Check the driving behaviour of the product after cleaning it.

#### 7.19.1 Cleaning

Clean the product regularly depending on the degree of soiling and frequency of use, **at least 1x per month**:

##### 7.19.1.1 Cleaning by hand

- 1) Clean the padding and upholstery with warm water and a mild detergent.
- 2) Remove any spots with a sponge or a soft brush.
- 3) Rinse with clear water and let the components dry.

##### **Important information on cleaning**

- Clean plastic parts, frame parts and the chassis and wheels with a mild cleaner and a damp cloth. Dry thoroughly afterwards.
- Do not use any aggressive cleaners, solvents or hard brushes etc.
- Do not spray the product with a pressure washer.



### 7.19.1.2 Cleaning the seat cushion

#### Standard seat cushion

- Clean the seat cushion according to the attached care label.

#### Seat cushion with foam core

- 1) Open the zipper and remove the foam core (see fig. 76).
- 2) Clean the cover according to the attached care label.
- 3) Wash all foam parts by hand at **40°C** using a mild, environmentally friendly detergent. Allow to air dry.
- 4) Reinsert the foam core with proper alignment. Close the zipper.



#### Important information on cleaning

- For more information on cleaning seat cushions, see the care instructions on the product or the supplied instructions for use.

### 7.19.1.3 Cleaning belts/straps

#### Cleaning a belt system with metal closure

##### INFORMATION

Observe the washing recommendations on the product and the information in the corresponding instructions for use provided for the product.

- Straps with metal closures **may not be washed in the washing machine** as the penetration of water could cause corrosion and subsequent malfunctions.
- Clean the belt straps by gently dabbing them with warm soapy water (with some disinfectant) or carefully wipe with a dry, clean, absorbent cloth.

#### Cleaning a belt system with plastic closure

- Depending on the model, belts/straps with plastic buckles can be washed in the washing machine between **40 °C** and **60 °C**.
- Recommendation: Use a laundry bag or net and mild detergent.

##### INFORMATION

Alternatively, the belt straps can be cleaned by gently dabbing them with warm soapy water (with some disinfectant) or carefully wiped with a dry, clean, absorbent cloth.

#### Additional cleaning instructions

- Allow the belts to air dry. Ensure that the belts and pads are completely dry before installation.
- Do not expose the belts to direct heat (e.g. sunshine, stove or radiator).
- Do not iron or bleach the belts.

### 7.19.2 Disinfection

- 1) Thoroughly clean the pads and handles before disinfecting.
- 2) Wipe all parts of the wheelchair with a disinfectant.

#### Important information about disinfecting

- If the product is used by more than one person, using a conventional disinfectant is required.
- Only use colourless water-based disinfectants. Observe the instructions for use provided by the manufacturer.

## 8 Maintenance and repair

### 8.1 Maintenance

**⚠ WARNING**

**Insufficient maintenance**

Severe user injuries, damage to the product due to failure to observe maintenance intervals

- ▶ Only carry out the maintenance tasks described in this section. All other maintenance and service tasks may only be carried out by qualified personnel.
- ▶ The functionality and operating safety of the product must be verified and a service performed at least **once per year**.
- ▶ For users with a changing anatomy (for example body dimensions, weight) or users with a changing clinical picture, have the product inspected, adjusted and serviced at least **once every six months**.

- The function of the product should be checked **before each use**.
- The product may not be used if defects are noted. This applies in particular in case of instability of the product or altered driving characteristics as well as problems with the user's seating position or the stability of the seat. Inform the qualified personnel promptly for the rectification of defects.
- This also applies if loose, worn, bent or damaged components, cracks in the frame or broken frame components are identified.
- Some maintenance tasks can be carried out to a certain extent by the user at home (see the sections "Maintenance intervals" and "Maintenance tasks").
- Failure to maintain the product can lead to injuries for the user of the product.

#### 8.1.1 Maintenance intervals

The functions described below must be checked by the user or an attendant at the specified intervals:

Inspection task	Before each use	Monthly	Quarterly
Functional test of the wheel locks	X		
Sagging of the seat or back upholstery		X	
Stability of the legrests		X	
Visual inspection of wear and tear parts (e.g., tyres, bearings)		X	
Soiling of bearings		X	
Damage to the handrim		X	
Air pressure (information see tyre sidewall)		X	
Wear and tear of the folding device		X	
Check of the spoke tension on the drive wheels			X
Check of all bolted connections			X
Check the legibility of all labels and markings on the product		X	

#### 8.1.2 Maintenance tasks

To ensure smooth operation at all times, users or attendants with some technical skills can maintain some parts of the product:

- Screw connections must be periodically checked for tightness, especially during the initial period of use or after adjustments have been made to the wheelchair. If a screw connection loosens repeatedly, contact the qualified personnel promptly.
- Particles of dirt and hair accumulate on the caster wheel axle and threaded axle of the caster fork over time. This makes the steering stiffer. Regularly remove dirt and oil the axles. See the section "Approach in case of stiffness".
- The drive wheels are equipped with a quick-release axle system as standard equipment. To keep this system operational, ensure that no dirt adheres to the quick-release axle or receiver bushing. Periodically lubricate the quick-release axle lightly with thin, resin-free oil (sewing machine oil).
- If the wheelchair becomes wet, it should be rubbed dry again.

## 8.2 Repair

### ⚠ WARNING

#### Prohibited repairs

Severe user injuries, damage to the product due to adjustment and installation errors

- ▶ Only carry out the repairs described in this section. All other repairs may only be carried out by the qualified personnel.

### 8.2.1 Inner tube, rim tape and tyre replacement

### ⚠ CAUTION

#### Improper tyre replacement

Injuries to the user due to incorrect installation, product damage

- ▶ No person is permitted to sit in the wheelchair during tyre replacement
- ▶ Before removing a wheel, support the product so it cannot tip over.
- ▶ Always replace the tyres in pairs. Two differently worn tyres affect the directional stability of the wheelchair.

### INFORMATION

When driving outdoors, always carry a repair kit and tyre pump (when using pneumatic tyres) in case of emergency.

Suitable tyre pumps are listed on the order form and are supplied with the product. An alternative is tyre foam, which fills your tyre and then hardens (available from bicycle shops, etc.).

Repairing flat tyres requires only the necessary tools and users may change tyres themselves if they wish:

#### Removal and preparing for installation

- 1) Carefully remove the tyre from the rim using appropriate tools.  
**INFORMATION: Take care not to damage the rim or the inner tube.**
- 2) Unscrew the valve nut from the valve and remove the tube.
- 3) Repair the tube according to the directions in the repair kit or replace it with a new tube.
- 4) Before fitting the tyre again, inspect the rim bed and tyre inner wall for foreign objects. This could have caused the puncture.
- 5) Before installing the tube, check that the rim band is in proper condition. The rim band protects the tube from being damaged by the ends of the spokes.



#### Replacing the rim band (only when necessary)

- 1) If the rim band needs to be replaced, remove it from the rim.
- 2) Install the new rim band on the inside of the rim, making sure the valve opening is in the right position.
- 3) Glue the rim band in place if this is intended. Ensure that all spoke ends are covered.

#### Installing the tube and tyre

- 1) Behind the valve, push one side of the tyre over the edge of the rim.
- 2) Slightly inflate the tube until it starts to assume its round shape.
- 3) Unscrew the valve nut from the tube and push the valve through the valve opening in the rim.

- 4) Insert the tube into the tyre.
- 5) Mount the other side of the tyre on the rim, starting from the position across the valve. Ensure that the tube is not pinched between the tyre and rim during this process.



### Inflating the tube

- 1) Ensure that the valve is positioned perpendicularly for proper positioning of the tube and tyre in the region of the valve.
- 2) Firmly screw on the valve nut.
- 3) Inflate the tube so that the tyre can still be pressed in easily with your thumb.  
**INFORMATION: If the circumferential lines on the two sides of the tyre are both at an even distance from the rim, the tyre is centred. If not, let some air out and realign the tyre.**
- 4) Inflate the tube to the maximum pressure specified by the tyre manufacturer (see information printed on the tyre sidewall).
- 5) Firmly screw the valve cap onto the valve.

## 9 Disposal

### 9.1 Disposal information

Return the product to the qualified personnel for disposal.

All components of the product must be disposed of properly in accordance with the respective national environmental regulations.

## 10 Legal information

All legal conditions are subject to the respective national laws of the country of use and may vary accordingly.

### 10.1 Liability

The manufacturer will only assume liability if the product is used in accordance with the descriptions and instructions provided in this document. The manufacturer will not assume liability for damage caused by disregarding the information in this document, particularly due to improper use or unauthorised modification of the product.

### 10.2 Warranty

Further information on the warranty terms and conditions can be obtained from the qualified personnel that has fitted this product or the manufacturer's service (see inside back cover for addresses).

### 10.3 Service life

Expected lifetime: **4 years**

The design, manufacturing and requirements for the intended use of the product are based on the expected lifetime. These also include the requirements for maintenance, ensuring effectiveness and the safety of the product.

## 11 Technical data

### INFORMATION

- ▶ Much of the technical data below is given in mm. Please note that product settings – unless otherwise specified – cannot be adjusted in the mm range but only in increments of approx. **0.5 cm** or **1 cm**.
- ▶ Note that the values achieved during adjustment may deviate from the values specified below. The deviation can be **±10 mm** and **±2°**.

### Avantgarde DS/DV – general information

	DS	DV
Max. load [kg]	140 <sup>1)</sup>	140 <sup>1)</sup>
Weight [kg]	From 8.7 <sup>2)</sup>	From 9.7 <sup>2)</sup>
Transport weights [kg]	Frame: from 6.1 <sup>2)</sup> 24" drive wheel: from 1.3 (including quick-release axle) <sup>2)</sup>	Frame: from 5.6 <sup>2)</sup> Leg support: from 0.75 <sup>2)</sup> 24" drive wheel: from 1.3 (including quick-release axle) <sup>2)</sup>
Seat width [mm]	320–520	320–520
Front seat height [mm]	380–540	380–540
Rear seat height [mm]	360–510	360–510
Seat depth [mm]	360–540	360–540
Overall length [mm]	720–1040 <sup>3)</sup>	720–1040 <sup>3)</sup>
Overall width [mm]	490–725	490–725
Overall height [mm]	580–1100	580–1100
Folding size from [mm]	260	260
Back support angle [°]	-9–+30	-9–+30
Back support height [mm]	250–550	250–550
Lower leg length [mm]	160–550	160–550
Angle leg support to seat bottom [°]	0–15	0–15
Distance from arm support to seat [mm]	245–340	245–340
Positioning of the arm support [mm]	175–250	175–250
Horizontal axle position [mm]	32.5–150.5	32.5–150.5
Anterior frame angle [°]	70/80	75
Drive wheels	22", 24", 25"	22", 24", 25"
Caster wheels	3", 4", 5", 5.5", 6"	3", 4", 5", 5.5", 6"
Permissible tyre type	Pneumatic, PU or solid rubber/ 1", 1 3/8"	Pneumatic, PU or solid rubber/ 1", 1 3/8"
Min. tyre pressure [bar]	7 <sup>4)</sup>	7 <sup>4)</sup>
Minimum turning radius [mm] <sup>5)</sup>	560–740	560–740
Handrim diameter [mm]	470–560	470–560
Maximum permissible inclination [°]/[%] <sup>6)7)8)</sup>	7/12.3	7/12.3

<sup>1)</sup> With CLT, CLT Ultra option: 100 kg

<sup>2)</sup> The specified weights vary according to the selected options and model.

<sup>3)</sup> +95 mm with wheelbase extension

<sup>4)</sup> Varies according to tyre option; see the marking on the tyre wall.

<sup>5)</sup> In accordance with ISO 7176-5.

<sup>6)</sup> Also applies for parking with wheel lock engaged.

<sup>7)</sup> Applies to all directions (upwards, downwards, sideways).

<sup>8)</sup> In accordance with ISO 7176-1.

### Ambient conditions

Temperatures and relative humidity	
Operating temperature [°C (°F)]	-10 to +40 (14 to 104)

<b>Temperatures and relative humidity</b>	
Transport and storage temperature [°C (°F)]	-10 to +40 (14 to 104)
Relative humidity [%]	45 to 85; non-condensing

## 12 Appendices

### 12.1 Threshold values for wheelchairs transportable by train

#### INFORMATION

- ▶ The products in this series fully satisfy the minimum technical requirements of regulation (EU) No. 1300/2014 regarding train accessibility for people with disabilities. However, not all versions can comply with all threshold values due to different settings.
- ▶ With the help of the table that follows, you or the qualified personnel can take measurements and verify whether the specific product in question meets the threshold values.

<b>Feature</b>	<b>Threshold value (according to Directive (EU) No. 1300/2014)</b>
Length [mm]	1200 (plus 50 mm for the feet)
Width [mm]	700 (plus 50 mm on each side for the hands when moving)
Smallest wheels ["]	approx. 3 or greater (according to the directive, the smallest wheel must be able to overcome a gap measuring 75 mm horizontally and 50 mm vertically)
Height [mm]	max. 1375; including a 1.84 m large male wheelchair user (95th percentile)
Turning radius [mm]	1500
Maximum weight [kg]	200 (for wheelchair and user, including any baggage)
Maximum obstacle height that can be overcome [mm]	50
Ground clearance [mm]	60 (at an upward slope angle of 10°, ground clearance must measure at least 60 mm under the footrest for going forward at the end of the slope)
Maximum inclination angle on which the wheelchair will remain stable [°]	6 (dynamic stability in all directions) 9 (static stability in all directions, also when wheel lock engaged)

# Kundenservice/Customer Service

## Europe

Otto Bock HealthCare Deutschland GmbH  
Max-Näder-Str. 15 · 37115 Duderstadt · Germany  
T +49 5527 848-3433 · F +49 5527 848-1460  
healthcare@ottobock.de · www.ottobock.de

Otto Bock Healthcare Products GmbH  
Brehmstraße 16 · 1110 Wien · Austria  
F +43 1 5267985  
service-admin.vienna@ottobock.com · www.ottobock.at

Otto Bock Adria d.o.o. Sarajevo  
Ramiza Salčina 85  
71000 Sarajevo · Bosnia-Herzegovina  
T +387 33 255-405 · F +387 33 255-401  
obadria@bih.net.ba · www.ottobockadria.com.ba

Otto Bock Bulgaria Ltd.  
41 Tzar Boris III<sup>rd</sup> Blvd. · 1612 Sofia · Bulgaria  
T +359 2 80 57 980 · F +359 2 80 57 982  
info@ottobock.bg · www.ottobock.bg

Otto Bock Suisse AG  
Luzerner Kantonsspital 10 · 6000 Luzern 16 · Suisse  
T +41 41 455 61 71 · F +41 41 455 61 70  
suisse@ottobock.com · www.ottobock.ch

Otto Bock ČR s.r.o.  
Protetická 460 · 33008 Zruč-Senec · Czech Republic  
T +420 377825044 · F +420 377825036  
email@ottobock.cz · www.ottobock.cz

Otto Bock Iberica S.A.  
C/Majada, 1 · 28760 Tres Cantos (Madrid) · Spain  
T +34 91 8063000 · F +34 91 8060415  
info@ottobock.es · www.ottobock.es

Otto Bock France SNC  
4 rue de la Réunion · CS 90011  
91978 Courtaboeuf Cedex · France  
T +33 1 69188830 · F +33 1 69071802  
information@ottobock.fr · www.ottobock.fr

Otto Bock Healthcare plc  
32, Parsonage Road · Englefield Green  
Egham, Surrey TW20 0LD · United Kingdom  
T +44 1784 744900 · F +44 1784 744901  
bockuk@ottobock.com · www.ottobock.co.uk

Otto Bock Hungária Kft.  
Tatai út 74. · 1135 Budapest · Hungary  
T +36 1 4511020 · F +36 1 4511021  
info@ottobock.hu · www.ottobock.hu

Otto Bock Adria d.o.o.  
Dr. Franje Tuđmana 14 · 10431 Sveta Nedelja · Croatia  
T +385 1 3361 544 · F +385 1 3365 986  
ottobockadria@ottobock.hr · www.ottobock.hr

Otto Bock Italia Srl Us  
Via Filippo Turati 5/7 · 40054 Budrio (BO) · Italy  
T +39 051 692-4711 · F +39 051 692-4720  
info.italia@ottobock.com · www.ottobock.it

Otto Bock Benelux B.V.  
Mandenmaker 14 · 5253 RC  
Nieuwkuijk · The Netherlands  
T +31 73 5186488 · F +31 73 5114960  
info.benelux@ottobock.com · www.ottobock.nl

Industria Ortopédica Otto Bock Unip. Ltda.  
Av. Miguel Bombarda, 21 - 2º Esq.  
1050-161 Lisboa · Portugal  
T +351 21 3535587 · F +351 21 3535590  
ottobockportugal@mail.telepac.pt

Otto Bock Polska Sp. z o. o.  
Ulica Koralowa 3 · 61-029 Poznań · Poland  
T +48 61 6538250 · F +48 61 6538031  
ottobock@ottobock.pl · www.ottobock.pl

Otto Bock Romania srl  
Șos de Centura Chitila - Mogoșoia Nr. 3  
077405 Chitila, Jud. Ilfov · Romania  
T +40 21 4363110 · F +40 21 4363023  
info@ottobock.ro · www.ottobock.ro

OOO Otto Bock Service  
p/o Pultikovo, Business Park „Greenwood”,  
Building 7, 69 km MKAD  
143441 Moscow Region/Krasnogorskiy Rayon  
Russian Federation  
T +7 495 564 8360 · F +7 495 564 8363  
info@ottobock.ru · www.ottobock.ru

Otto Bock Scandinavia AB  
Koppargatan 3 · Box 623 · 60114 Norrköping · Sweden  
T +46 11 280600 · F +46 11 312005  
info@ottobock.se · www.ottobock.se

Otto Bock Slovakia s.r.o.  
Röntgenova 26 · 851 01 Bratislava 5 · Slovak Republic  
T +421 2 32 78 20 70 · F +421 2 32 78 20 89  
info@ottobock.sk · www.ottobock.sk

Otto Bock Sava d.o.o.  
Industrijska bb · 34000 Kragujevac · Republika Srbija  
T +381 34 351 671 · F +381 34 351 671  
info@ottobock.rs · www.ottobock.rs

Otto Bock Ortopedi ve  
Rehabilitasyon Tekniği Ltd. Şti.  
Mecidiyeköy Mah. Lati Lokum Sok.  
Meriç Sitesi B Blok No: 30/B  
34387 Mecidiyeköy-Istanbul · Turkey  
T +90 212 3565040 · F +90 212 3566688  
info@ottobock.com.tr · www.ottobock.com.tr

## Africa

Otto Bock Algérie E.U.R.L.  
32, rue Ahcène Outaleb - Coopérative les Mimosas  
Mackle-Ben Aknoun · Alger · DZ Algérie  
T +213 21 913863 · F +213 21 913863  
information@ottobock.fr · www.ottobock.fr

Otto Bock Egypt S.A.E.  
28 Soliman Abaza St. Mohandessein · Giza · Egypt  
T +20 2 37606818 · F +20 2 37605734  
info@ottobock.com.eg · www.ottobock.com.eg

Otto Bock South Africa (Pty) Ltd  
Building 3 Thornhill Office Park · 94 Bekker Road  
Midrand · Johannesburg · South Africa  
T +27 11 564 9360  
info-southafrica@ottobock.co.za  
www.ottobock.co.za

## Americas

Otto Bock Argentina S.A.  
Av. Belgrano 1477 · CP 1093  
Ciudad Autónoma de Buenos Aires · Argentina  
T +54 11 5032-8201 / 5032-8202  
atencionclientes@ottobock.com.ar  
www.ottobock.com.ar

Otto Bock do Brasil Tecnica Ortopédica Ltda.  
Alameda Maria Tereza, 4036, Bairro Dois Córregos  
CEP: 13.278-181, Valinhos-São Paulo · Brasil  
T +55 19 3729 3500 · F +55 19 3269 6061  
ottobock@ottobock.com.br · www.ottobock.com.br

Otto Bock HealthCare Canada  
5470 Harvester Road  
Burlington, Ontario, L7L 5N5, Canada  
T +1 800 665 3327 · F +1 800 463 3659  
CACustomerService@ottobock.com  
www.ottobock.ca

Oficina Ottobock Habana  
Calle 3ra entre 78 y 80.  
Edificio Jerusalem · Oficina 112 · Calle 3ra.  
Playa, La Habana. Cuba  
T +53 720 430 69 · +53 720 430 81  
hector.corcho@ottobock.com.br  
www.ottobock.com.br

Otto Bock HealthCare Andina Ltda.  
Calle 138 No 53-38 · Bogotá · Colombia  
T +57 1 8619988 · F +57 1 8619977  
info@ottobock.com.co · www.ottobock.com.co

Otto Bock de Mexico S.A. de C.V.  
Prolongación Calle 18 No. 178-A  
Col. San Pedro de los Pinos  
C.P. 01180 México, D.F. · Mexico  
T +52 55 5575 0290 · F +52 55 5575 0234  
info@ottobock.com.mx · www.ottobock.com.mx

Otto Bock HealthCare LP  
11501 Alterra Parkway Suite 600  
Austin, TX 78758 · USA  
T +1 800 328 4058 · F +1 800 962 2549  
USCustomerService@ottobock.com  
www.ottobockus.com

## Asia/Pacific

Otto Bock Australia Pty. Ltd.  
Suite 1.01, Century Corporate Centre  
62 Norwest Boulevard  
Baulkham Hills NSW 2153 · Australia  
T +61 2 8818 2800 · F +61 2 8814 4500  
healthcare@ottobock.com.au · www.ottobock.com.au

Beijing Otto Bock Orthopaedic Industries Co., Ltd.  
B12E, Universal Business Park  
10 Jiuxianqiao Road, Chao Yang District  
Beijing, 100015, P.R. China  
T +8610 8598 6880 · F +8610 8598 0040  
news-service@ottobock.com.cn  
www.ottobock.com.cn

Otto Bock Asia Pacific Ltd.  
Unit 1004, 10/F, Greenfield Tower, Concordia Plaza  
1 Science Museum Road, Tsim Sha Tsui  
Kowloon, Hong Kong · China  
T +852 2598 9772 · F +852 2598 7886  
info@ottobock.com.hk · www.ottobock.com

Otto Bock HealthCare India Pvt. Ltd.  
20th Floor, Express Towers  
Nariman Point, Mumbai 400 021 · India  
T +91 22 2274 5500 / 5501 / 5502  
information@indiaottobock.com · www.ottobock.in

Otto Bock Japan K. K.  
Yokogawa Building 8F, 4-4-44 Shibaura  
Minato-ku, Tokyo, 108-0023 · Japan  
T +81 3 3798-2111 · F +81 3 3798-2112  
ottobock@ottobock.co.jp · www.ottobock.co.jp

Otto Bock Korea HealthCare Inc.  
4F Agaworld Building · 1357-74, Seocho-dong  
Seocho-ku, 137-070 Seoul · Korea  
T +82 2 577-3831 · F +82 2 577-3828  
info@ottobockkorea.com · www.ottobockkorea.com

Otto Bock South East Asia Co., Ltd.  
1741 Phaholyothin Road  
Kwaeng Chatuchark · Khet Chatuchark  
Bangkok 10900 · Thailand  
T +66 2 930 3030 · F +66 2 930 3311  
obsea@ottobock.co.th · www.ottobock.co.th

## Other countries

Ottobock SE & Co. KGaA  
Max-Näder-Straße 15 · 37115 Duderstadt · Germany  
T +49 5527 848-1590 · F +49 5527 848-1676  
reha-export@ottobock.de · www.ottobock.com

Ihr Fachhändler | Your specialist dealer



Otto Bock Mobility Solutions GmbH  
Lindenstraße 13 · 07426 Königsee/Germany  
[www.ottobock.com](http://www.ottobock.com)

